

SMART
MACHINE TOOL

NL 1500/2000/2500/3000

High performance CNC Turning Centers



INAXES
CNC MACHINERY

WWW.CNC-INAXES.CZ

NL Series

NL 1500, NL 2000
NL 2500, NL 3000

Chuck Size

6", 8", 10", 12"

NL Series

Designed by Smart Machine Tool engineers with many years of experience, NL Series turning centers guarantee ultra-high precision, flexible, and reliable machining performance.



		NL 1500 1500M	NL 2000 2000M	NL 2000B 2000BM	NL 2500S 2500SM
Swing Over Bed	mm	570	570	570	570
Max. Machining Length	mm	560 540	560 540	550 540	530 480
Chuck Size	mm	153 (6")	203 (8")	254 (10")	254 (10")
Bar Capacity	mm	52	68	82	82
Spindle Speed	rpm	6,000	4,500	3,500	3,500 [4,000]
Motor (Cont./Max)	kW	11/18.5	15/18.5	15/18.5	15/18.5 [22/35]
Max. Torque	N.m	157	336	447	1,256 [1,336]
No. of Tools	EA	12	12	12	12

NL 1500 | 2000 | 2500 | 3000

- 45° slanted torque tube design bed and wide slideway for high rigidity machining
- Wide box guideways machined from one-piece casting promote heavy duty cutting
- High torque AC servo motor ensures fast indexing time and repeatability
- Excellence rapid traverse rate: 30m/min (Z-axis)
- High spindle power ensures powerful cutting capability
- User-friendly operation panel design for efficient machine operation
- Various peripheral equipment and options



NL 2500 | **2500M**

NL 2500L | **2500LM**

NL 3000B | **3000BM**

NL 3000BL | **3000BLM**

		NL 2500 2500M	NL 2500L 2500LM	NL 3000B 3000BM	NL 3000BL 3000BLM
Swing Over Bed	mm	700	700	700	700
Max. Machining Length	mm	750 700	1,100 1,050	750 700	1,100 1,050
Chuck Size	mm	254 (10")	254 (10")	305 (12")	305 (12")
Bar Capacity	mm	82	82	103	103
Spindle Speed	rpm	3,500 [4,000]	3,500 [4,000]	2,800	2,800
Motor (Cont./Max)	kW	15/18.5 [22/35]	15/18.5 [22/35]	22/35	22/35
Max. Torque	N.m	1,256 [1,336]	1,256 [1,336]	1,613	1,613
No. of Tools	EA	12	12	12	12

[] : Option

Machine Structure

High Rigidity Body Structure for Heavy-duty Machining

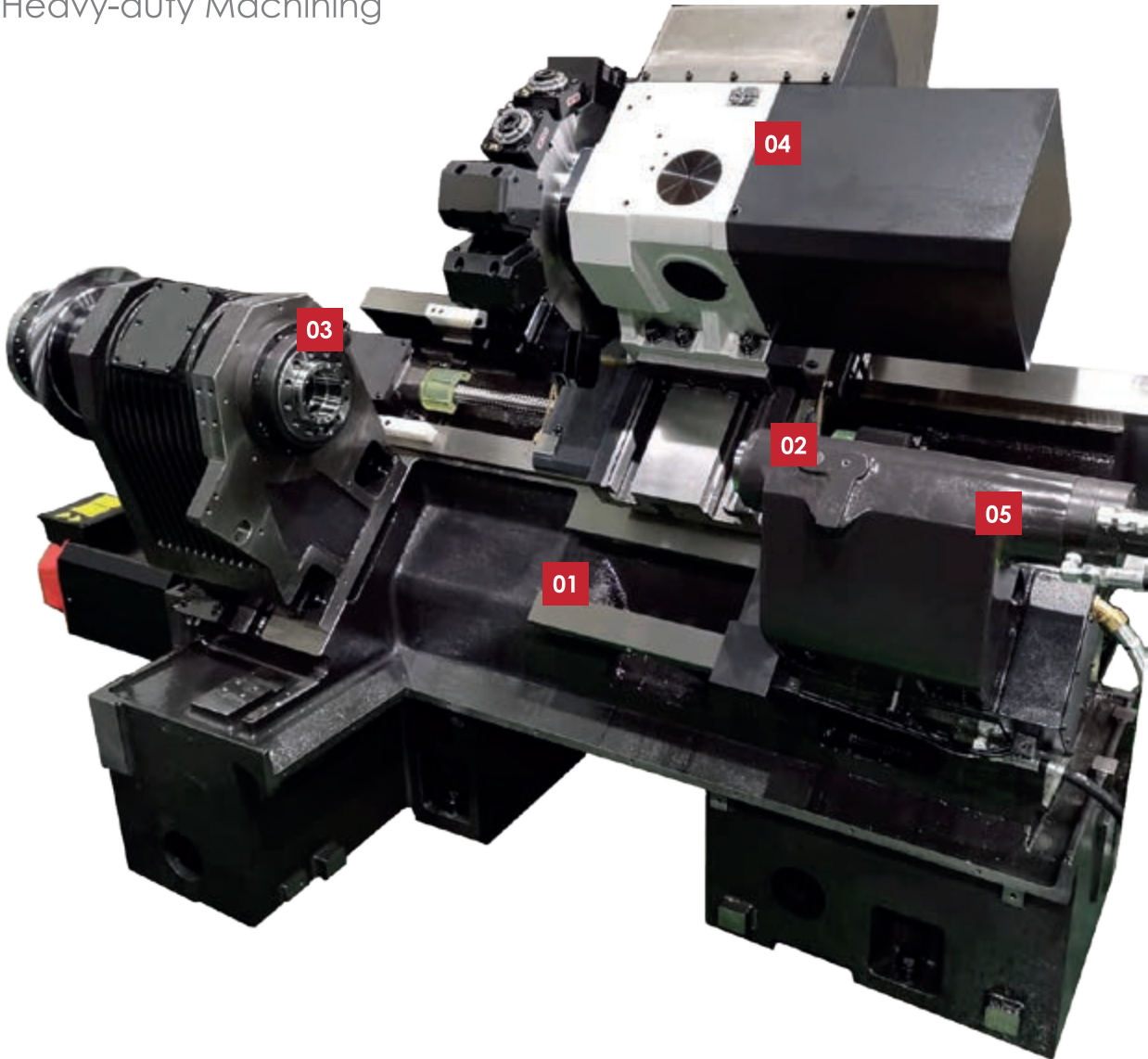

One-Piece Casting Bed

01

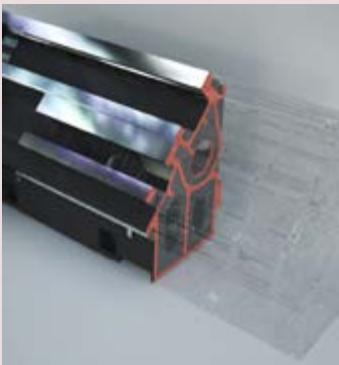

One-piece 45-degree slant bed made out of Meehanite cast iron, which has superb vibration absorption characteristics, provides rigid foundation for all machine components. Such design endures long-term machining accuracy and consistency. In addition, 45-degree slant bed design provides operators with convenient access to the workpiece and superb chip discharge.

- Precision hand scraping of contact surfaces of all slides, headstock and tailstock with the bed ensure long-lasting machining accuracy and minimal surface wears.



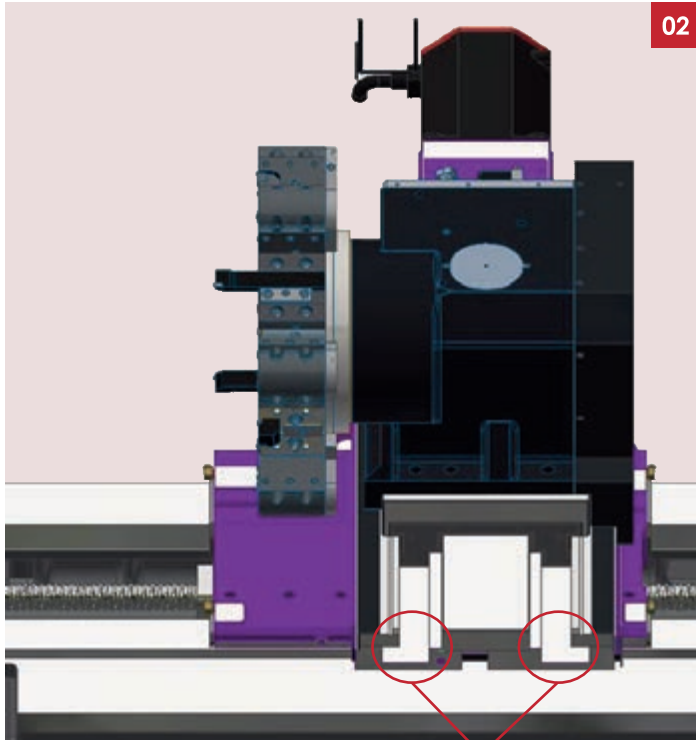

02

Z-Axis High Performance Motor

Z-axis is equipped with high performance feed motor for better travel ability.

Z-axis rapid traverse rate: 30 m/min

Wide box guideways and Carriage

Hexahedral design and wide box guideways, machined from one piece casting, promote heavy duty machining.

Induction hardened and precision ground ways ensure accurate machining for extended period of time.

Wide carriage promotes less vibration and allows high precision machining.

Hexahedral design



Pre-tensioned Ballscrews

All axes ballscrews are pre-tensioned, heat treated and fixed by double anchors on both ends, providing ultimate rigidity and minimal thermal growth.

04

12-Station Turret

Large diameter 3-piece Curvic coupling for excellence rigidity and extended tool life.

High torque AC servo motor driven ensure fast indexing time, excellence position and repeatability.

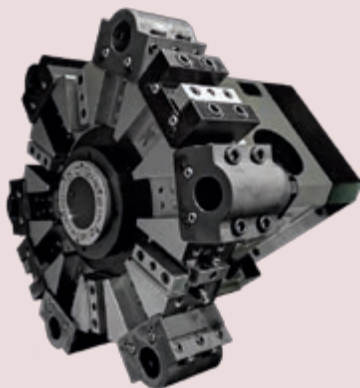

Main Spindle

03

Double row cylindrical roller bearings in the front and back, coupled with angular thrust bearing, ensure high rigidity for heavy cutting and excellent surface finishes.

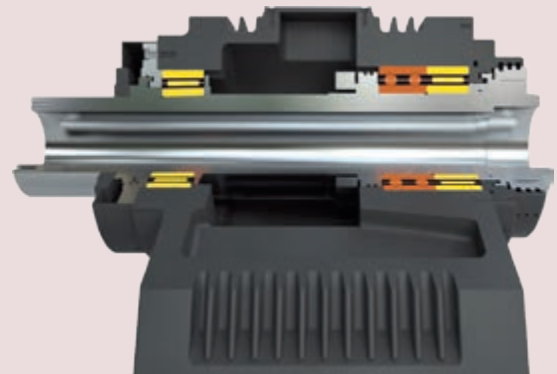

SMART
MACHINE TOOL

NL 1500/2000/2500/3000
CNC Turning Centers

Machine Structure

Programmable Tailstock Body & Quill

05

Wide-spaced guideways and heavy-duty tailstock body design ensure machining rigidity, and built in spindle quill design ensures higher rigidity.

NL 1500/2000

- Quill Type: **MT#4 (Live)**
- Quill Dia: **Ø80 mm**
- Quill Travel: **80 mm**

NL 2500/3000

- Quill Type: **MT#4 (Built-in)**
- Quill Dia: **Ø110 mm**
- Quill Travel: **100 mm**



Main Spindle

High Accuracy & Performance CNC Turning Center

Main Spindle

Heavy-duty headstock machined from one-piece casting. Reinforced with radiator fan-like pin tube rip design dissipates heat generated by axis movements, maintaining minimal thermal expansion.

		NL 1500	NL 2000	NL 2000B	NL 2500	NL 3000
Chuck size	mm	153 (6")	203 (8")	254 (10")	254 (10")	305 (12")
Spindle nose	ASA	A2-5	A2-6	A2-8	A2-8	A2-11
Max speed	rpm	6,000	4,500	3,500	3,500 [4,000]	2,800
Thru hole dia.	mm	Ø61	Ø76	Ø91	Ø91	Ø115
Draw tube I.D.	mm	Ø52	Ø68	Ø82	Ø82	Ø103

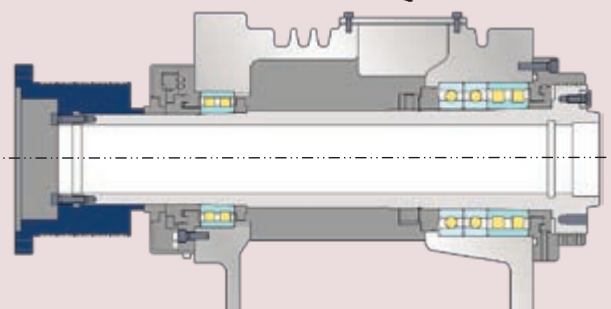

- Spindle pulley system is equipped with powerful and reliable Fanuc AC motor to ensure excellence heavy-duty cutting capability.
- PK type pulley belt is used to achieve low vibration, low noise and good surface roughness cutting result even at high speed.

NL 1500/2000

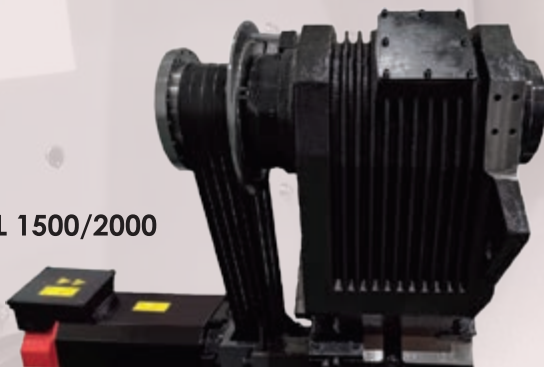

NL 2500/3000
(2-speed gearbox)

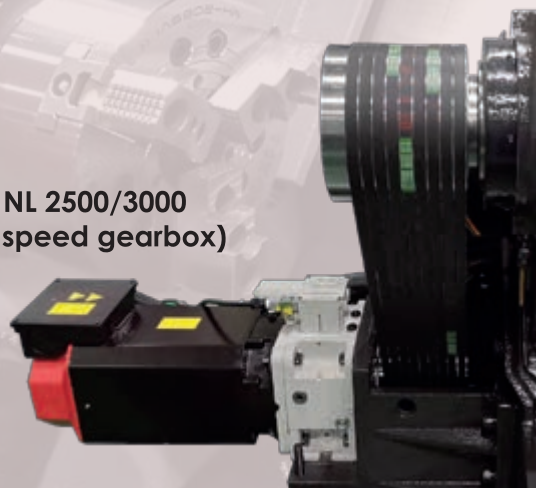

NL 1500 : 6,000 rpm

Max. Output	Max. Torque
18.5 kW	157 N.m

NL 2000 : 4,500 rpm

Max. Output	Max. Torque
18.5 kW	336 N.m

NL 2000B : 3,500 rpm

Max. Output	Max. Torque
18.5 kW	447 N.m

NL 2500 (Standard) : 3,500 rpm

Max. Output	Max. Torque
18.5 kW	1,256 N.m

NL 2500 (Option) : 4,000 rpm

Max. Output	Max. Torque
35 kW	1,336 N.m

NL 3000 : 2,800 rpm

Max. Output	Max. Torque
35 kW	1,613 N.m

Spindle Torque Diagram

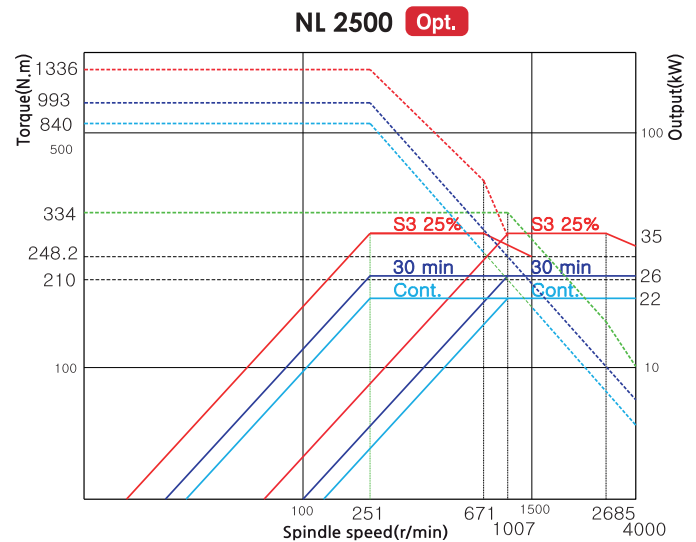
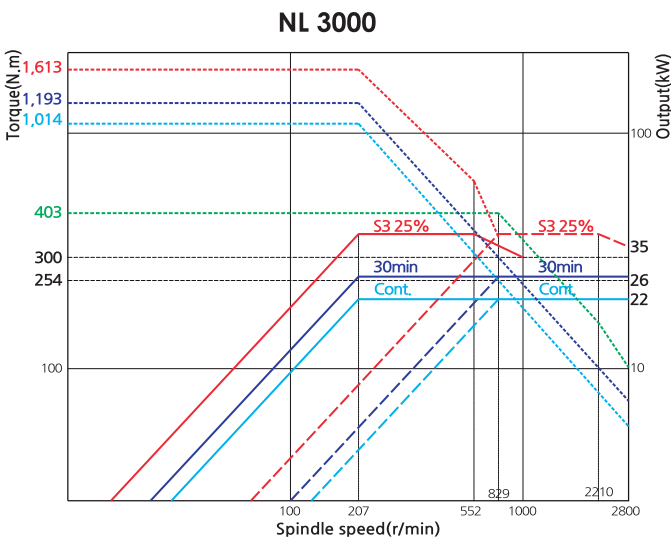
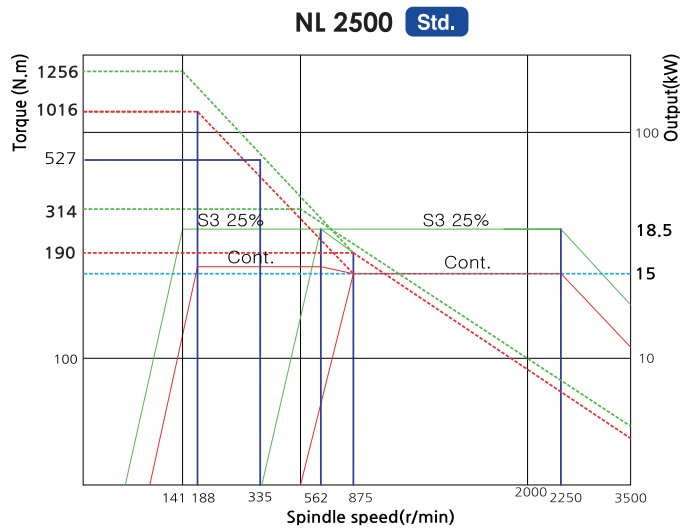
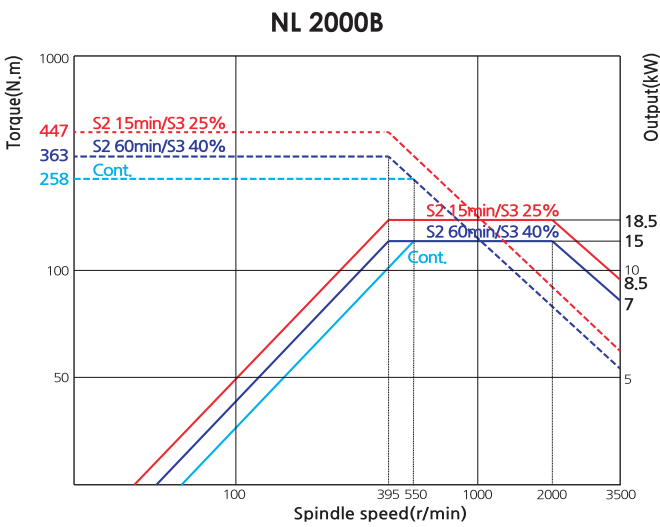
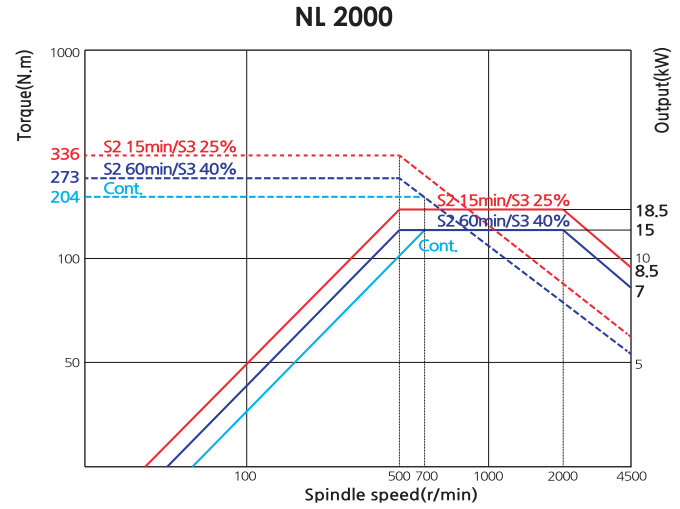
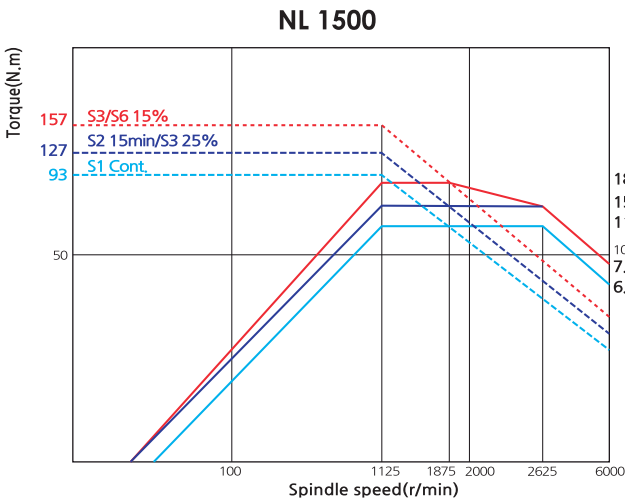

SMART MACHINE TOOL
NL 1500/2000/2500/3000 CNC Turning Centers
Main Spindle

Turret

Finest performance and high precision turret

Standard Turret

Heavy-duty turret driven by high torque AC servo motor for rapid rotation and repeatability. The turret design features large diameter Curvic coupling ensure accurate positioning and strong clamping power.

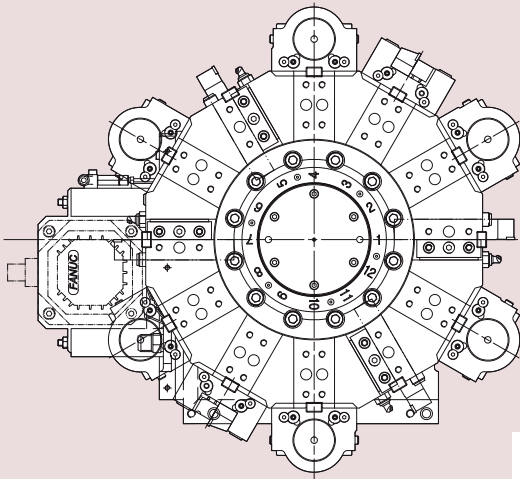

- No. of tools: **12 EA**
- Indexing time: **0.15 sec** (NL 1500/2000)
- Indexing time: **0.2 sec** (NL 2500/3000)



Tool Holder



Boring holder

NL 1500/2000: **Ø40 mm**
NL 2000B/2500/3000: **Ø50 mm**



Bite holder

□ 25 mm

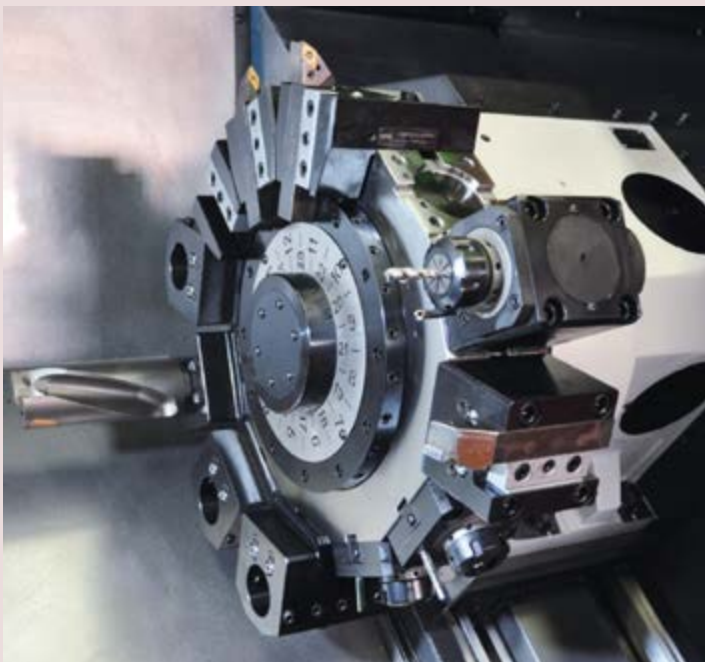

BMT Mill Turret

BMT turret is equipped with 2 separated motors for indexing and milling which improving machining performance and reducing processing time of workpiece.

Mill Tool Holder

Tool holder is mounted to BMT turret by 4 screws ensures stability, rigidity and heavy-duty machining operations.

Straight mill holder



Angular mill holder



■ Mill Tool Torque Diagram

BMT 55 (NL1500/2000)

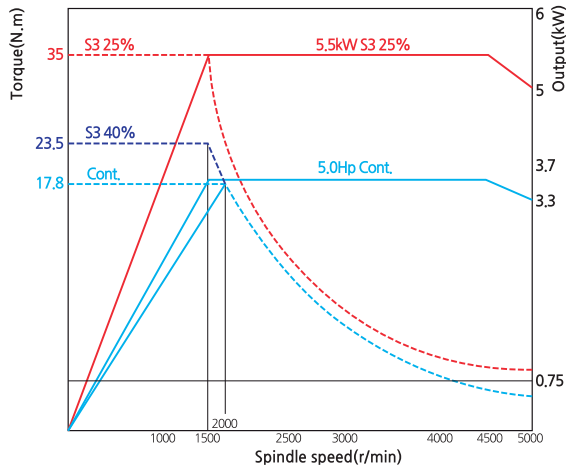

BMT 65 (NL2500/3000)

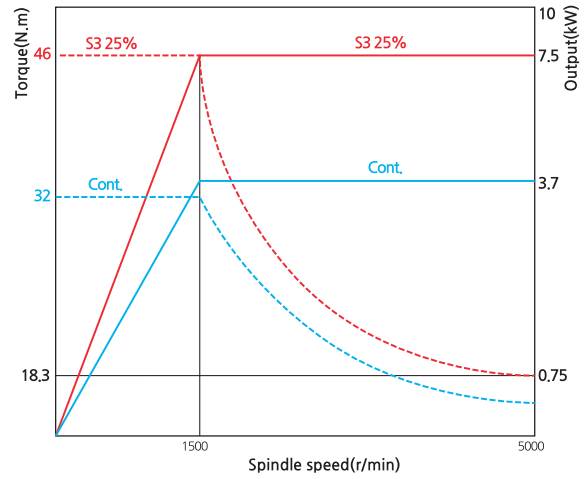

⬡ Tailstock

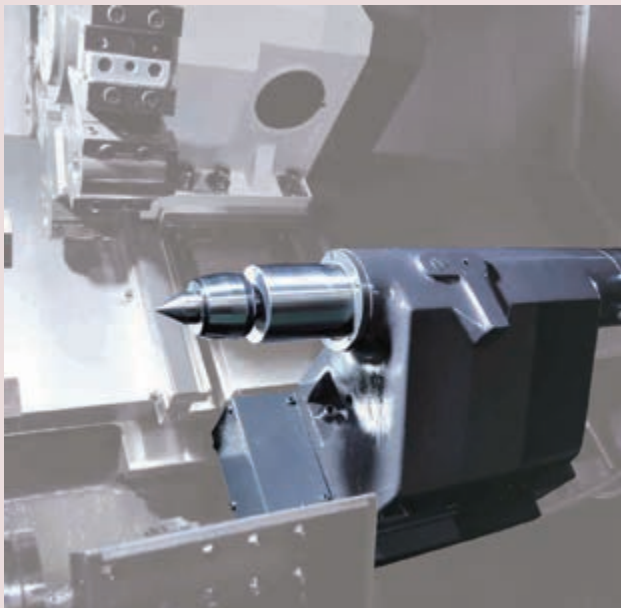

Programmable tailstock body & quill is provided as standard equipment for NL series, make easier to adjust tailstock position and minimize setup time.

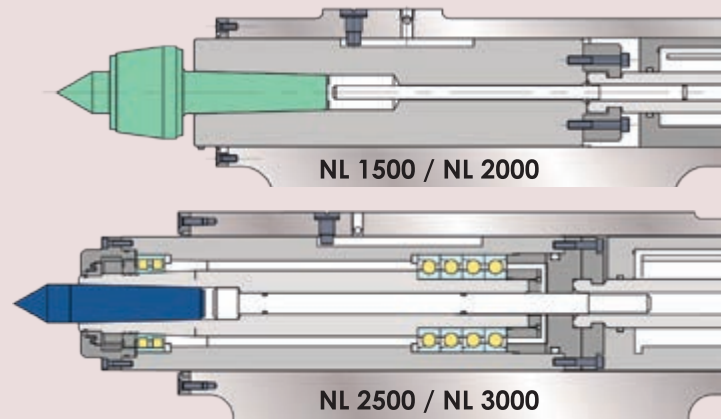

	NL 1500	NL 2000	NL 2500	NL 3000
Quill dia.	mm	Ø80		Ø110
Quill travel	mm	80		100
Taper	-	MT4 live		MT4 (built-in)
Hydraulic clamp	kgf	3,800		11,000
Hydraulic quill	kgf	515		1,008

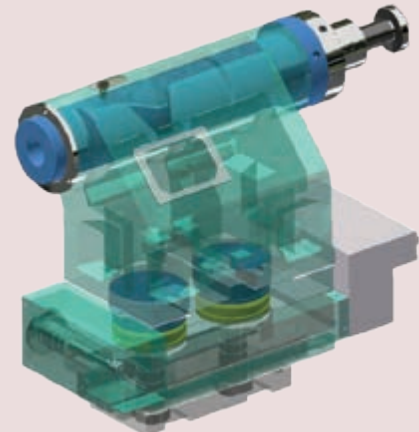

Ball screw

Ultimate rigidity ballscrew

Pre-Tensioned and Double Anchored Ballscrews

Both ends of X-axis and Z-axis are fixed and preloaded with P4 high precision Angular contact ball bearing ensure precise and smooth rotation.

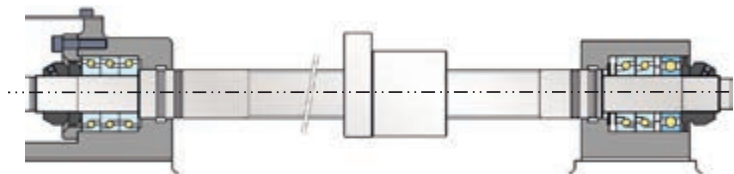

Z-Axis

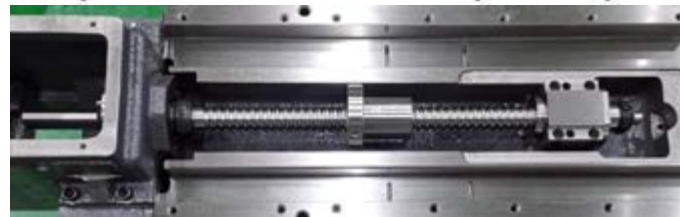

X-Axis

Machining Area

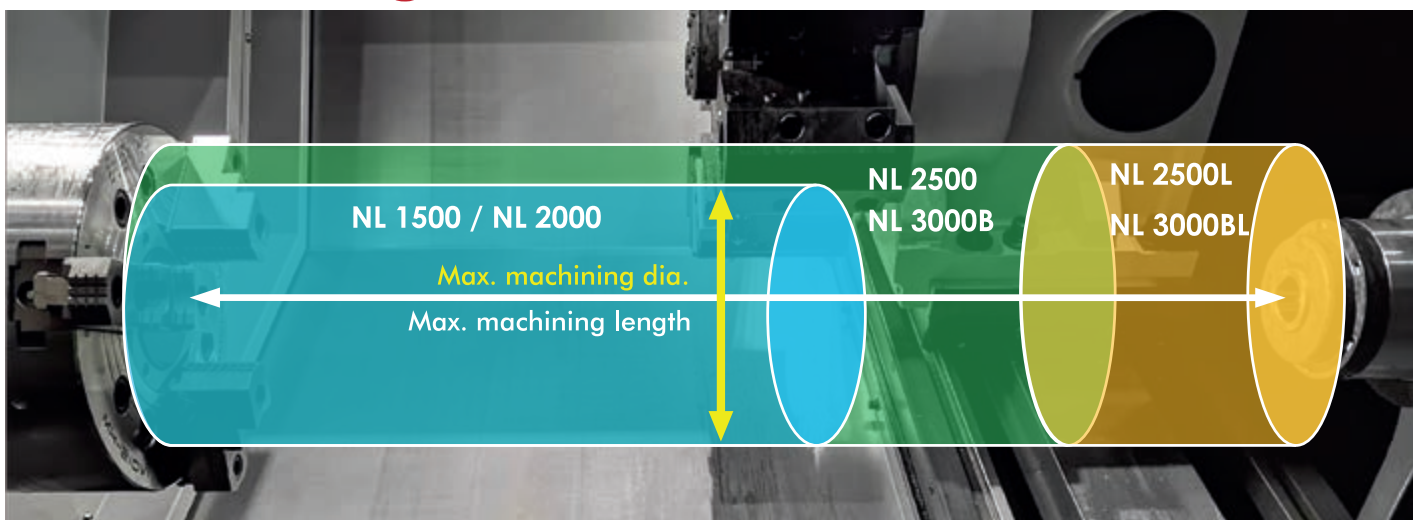

Model	Max. machining dia.	Max. machining length	Bar capacity	
NL 1500	Ø391	560	52	
NL 1500M	Ø381	540		
NL 2000	Ø391	560	68	
NL 2000M	Ø381	540		
NL 2000B	Ø391	550	82	
NL 2000BM	Ø381	540		
NL 2500S	Ø480	530	82	
NL 2500SM	Ø450	480		
NL 2500	Ø480	750		
NL 2500M	Ø450	700		
NL 2500L	Ø480	1,100		
NL 2500LM	Ø450	1,050		
NL 3000B	Ø480	750		103
NL 3000BM	Ø450	700		
NL 3000BL	Ø480	1,100		
NL 3000BLM	Ø450	1,050		

Cutting Performance



Heavy-duty cutting <O.D.>

Machine type	NL 2500
Material <JIS>	S45C
Spindle speed	367 min ⁻¹
Depth of cut	8 mm
Cutting speed	152 m/min.
Feedrate	0.5 mm/rev

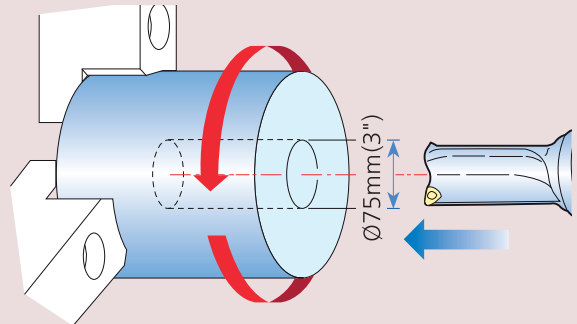

Insert Drill

Machine type	NL 2500
Material <JIS>	S45C
Spindle speed	417 min ⁻¹
Drill diameter	75 mm
Feedrate	0.15 mm/rev

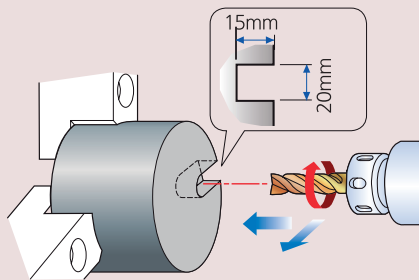

End mill <Ø20mm(0.8") High-speed steel>

Machine type	NL 2500
Material <JIS>	S45C
Rotary tool spindle speed	320 min ⁻¹
Depth of cut	15 mm
Cutting speed	20 m/min.
Feedrate	65 mm/min.

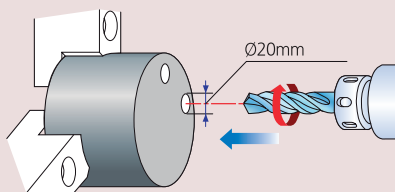

Drill <Ø20mm(0.8") High-speed steel>

Machine type	NL 2500
Material <JIS>	S45C
Rotary tool spindle speed	391 min ⁻¹
Cutting speed	25 m/min.
Feedrate	105 mm/min.

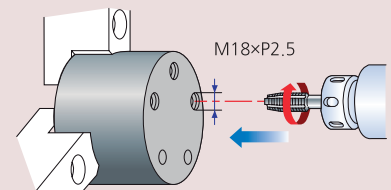

Tap <M18xP2.5>

Machine type	NL 2500
Material <JIS>	S45C
Rotary tool spindle speed	160 min ⁻¹
Cutting speed	10 m/min.
Feedrate	400 mm/min.

Roundness (Turning)

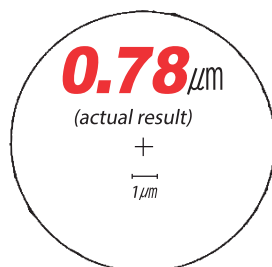

Machine type	Unit	NL 2500
Material	-	Brass (Ø80mm x L60mm)
Tool	-	Diamond tool
Cutting depth	mm	0.1
Feedrate	mm/rev	0.05
Nose radius	mm	0.5

Surface Roughness (Turning)

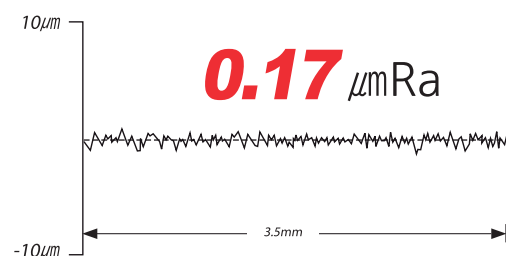

SMART Operation Features

Smart NL Series Turning Centers take operator convenience to the next level, offering key optional accessories as standard features of the machines.



BZi Sensor Std.

SMART provides BZi sensor as standard equipment, instead of position coder, for all models of NL series.

Use of BZi sensor helps reduce after sale service cost as BZi sensor does not require maintenance, unlike position coder which need regular service maintenance.

15 Inch Touchscreen Operation Panel Std.

15 inch touch type monitor with Fanuc iHMI as standard features, increase ease-of-use and improve operational efficiency.

Operator-friendly design and QWERTY keyboard layout for efficient machine operation. Protected sealed buttons to prevent letters and signs from wearing off.

Operator panel swivels up to 90 degrees, providing operators with easy access to the panel while working on the machine.

- 15 inch touchscreen
- QWERTY keyboard
- Fanuc iHMI
- Semi-permanent A/S LED lamping
- Waterproof button
- Big button size
- Replaceable button cap
- Light indicator at 100% driving status



Metered Lubrication System Std.



Automatic lubrication dispenser reliably dispenses exact amount of lubrication, only when axes is in operation.

In the event of lubrication line failure, the system generates a warning message on CRT and stops the machine for operation safety.

High Pressure Coolant Pump Std. / Oil Skimmer Std.



Standard high pressure coolant pump sufficiently cools off the heat generated while cutting, ensuring precision machining and extended tool life, while Oil Skimmer effectively removes oil from coolant.



Belt type oil skimmer



Easy plug-in / remove cable

Manual Guide i Std.



MGI enables operators to program and simulate part programs using a conversational programming without actually running the machine.

Programmable Tailstock and Quill Std.

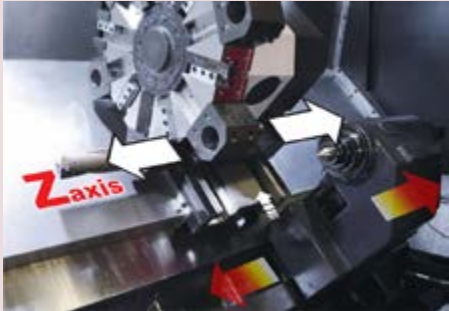

Programmable tailstock and quill make the set-up easier and faster.

Tool Presetter Std.



Tool presetter reduces set-up time by minimizing the need for manual skin cuts, measurement, and entering of tool offsets.

Chip Conveyor Std.

Equipped with wide hinged belt, worm gear reducer and torque limiter ensure stable movement and efficiently disposes of chips.



Highly Reliable Electrical Components Std.

Brake, power and relay circuits are integrated into one board system to minimize electrical system failure and easily to maintenance and service.

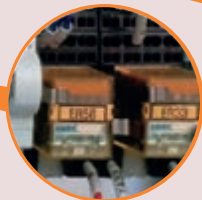
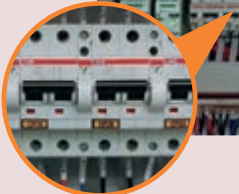
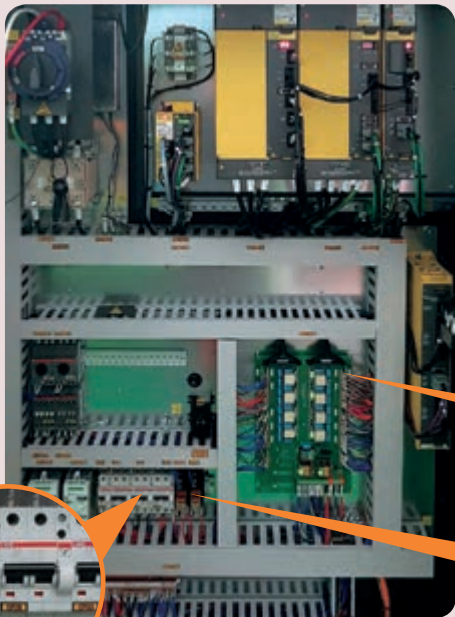

Service Oriented Sheet Metals Design Std.

Sheet metals are designed for easy access to the parts/units when service is needed.

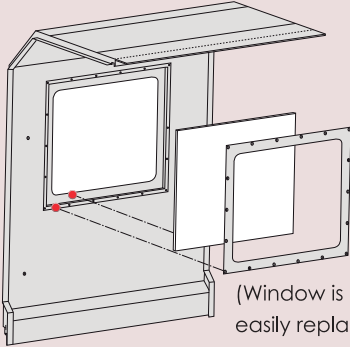

(Window is designed to be easily replaced)

SMART MACHINE TOOL

NL 1500/2000/2500/3000 CNC Turning Centers

Smart operation features

Features

Part Catcher Opt. Std.

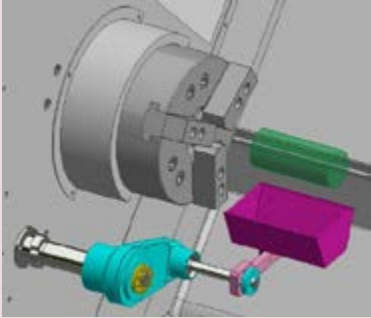

Automatically catches completed parts after cut-off.

CE Approved Foot Switch Std. / Air Gun & Coolant Gun Opt.

Connection-ready module design to easily add or remove accessories.



Dual Chuck Opt.

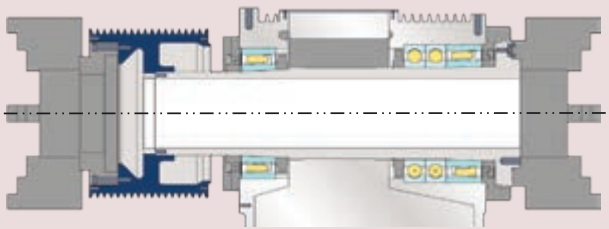

Dual chuck system helps improve machining stability for long workpiece by fix the workpiece at two positions.

Steady Rest Opt.

Steady rest supports turning long workpiece and prevent workpiece from trembling.



Model	SMW-AUTOBLOK	
	SLU-X 3	SLU-X 3.1/3.2
NL 1500	X	X
NL 2000	X	X
NL 2500	O	O
NL 3000	O	O

Re-Machining Function Opt.

This function allows user to easily repair damaged part.

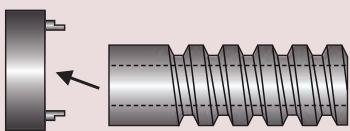

Step 1: Load the damaged part into the machine.

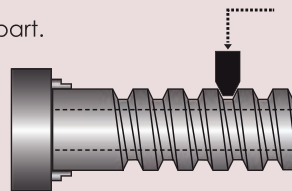

Step 2: Manually positioning the tool into the machined thread with the spindle stopped and then registering the position with the CNC.

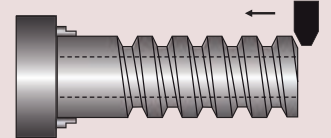

Step 3: Retract the tool, start the spindle and run the part program to re-machined the thread.

Arbitrary Speed Threading Opt.

Arbitrary speed threading ensures cutting tool remains coordinated with spindle speed at all time during threading. It allows user to adjust spindle speed during threading without damaging the part.

Spindle speed override change

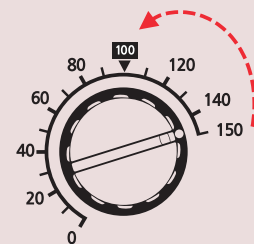
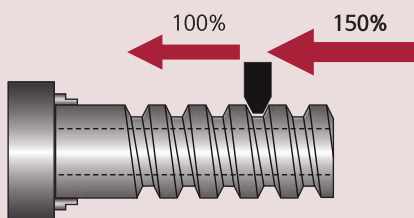

Spindle Override

Standard & Option Specifications

● : Standard ○ : Option X : Not applicable

		NL 1500		NL 2000				NL 2500						NL 3000			
		-	M	-	M	B	BM	-	M	S	SM	L	LM	B	BM	BL	BLM
Spindle and Chucking																	
Hydraulic chuck size	153 mm (6")	●	●	X	X	X	X	X	X	X	X	X	X	X	X	X	X
	203 mm (8")	X	X	●	●	X	X	X	X	X	X	X	X	X	X	X	X
	254 mm (10")	X	X	X	X	●	●	●	●	●	●	●	●	X	X	X	X
	305 mm (12")	X	X	X	X	X	X	○	○	○	○	○	○	●	●	●	●
Dual pressure chucking		○	○	○	○	○	○	○	○	○	○	○	○	○	○	○	○
Chuck clamp foot switch		●	●	●	●	●	●	●	●	●	●	●	●	●	●	●	●
Chuck clamp confirmation		●	●	●	●	●	●	●	●	●	●	●	●	●	●	●	●
Dual chuck		X	X	X	X	X	X	X	X	X	X	X	X	○	○	○	○
2 step gearbox		X	X	X	X	X	X	●	●	●	●	●	●	●	●	●	●
Jaw																	
Soft jaw	3 set	●	●	●	●	●	●	●	●	●	●	●	●	●	●	●	●
Hard jaw	1 set	●	●	●	●	●	●	●	●	●	●	●	●	●	●	●	●
Special chuck		○	○	○	○	○	○	○	○	○	○	○	○	○	○	○	○
Steady Rest																	
SLU-X 3	∅12~∅152 mm	X	X	X	X	X	X	○	○	X	X	○	○	○	○	○	○
SLU-X 3.1	∅20~∅165 mm	X	X	X	X	X	X	○	○	X	X	○	○	○	○	○	○
SLU-X 3.2	∅50~∅200 mm	X	X	X	X	X	X	○	○	X	X	○	○	○	○	○	○
Tailstock																	
Programmable tailstock		●	●	●	●	●	●	●	●	●	●	●	●	●	●	●	●
Tailstock taper	MT#4	●	●	●	●	●	●	●	●	●	●	●	●	●	●	●	●
Built-in live center		○	○	○	○	○	○	●	●	●	●	●	●	●	●	●	●
Tailstock in-out foot switch		●	●	●	●	●	●	●	●	●	●	●	●	●	●	●	●
Coolant																	
High pressure coolant pump	10 bar (140 psi)	●	●	●	●	●	●	●	●	●	●	●	●	●	●	●	●
	20 bar (290 psi)	○	○	○	○	○	○	○	○	○	○	○	○	○	○	○	○
Oil skimmer		●	●	●	●	●	●	●	●	●	●	●	●	●	●	●	●
Coolant chiller		○	○	○	○	○	○	○	○	○	○	○	○	○	○	○	○
Coolant filtration system	25 μm filter	○	○	○	○	○	○	○	○	○	○	○	○	○	○	○	○
Chuck coolant		○	○	○	○	○	○	○	○	○	○	○	○	○	○	○	○
Shower coolant		○	○	○	○	○	○	○	○	○	○	○	○	○	○	○	○
Coolant gun		○	○	○	○	○	○	○	○	○	○	○	○	○	○	○	○
Chip Disposal																	
Side chip conveyor		●	●	●	●	●	●	●	●	●	●	●	●	●	●	●	●
Rear chip conveyor		○	○	○	○	○	○	○	○	○	○	X	X	○	○	X	X
Chip bucket		○	○	○	○	○	○	○	○	○	○	○	○	○	○	○	○
Air gun		○	○	○	○	○	○	○	○	○	○	○	○	○	○	○	○
Air blower system		○	○	○	○	○	○	○	○	○	○	○	○	○	○	○	○
Oil mist collector		○	○	○	○	○	○	○	○	○	○	○	○	○	○	○	○
Measurement & Automatic Operation																	
Tool presetter		●	●	●	●	●	●	●	●	●	●	●	●	●	●	●	●
Auto door		○	○	○	○	○	○	○	○	○	○	○	○	○	○	○	○
Parts catcher		●	●	●	●	●	●	○	○	○	○	○	○	X	X	X	X
Others																	
Operation status light tower		●	●	●	●	●	●	●	●	●	●	●	●	●	●	●	●
Work light (LED lamp)		●	●	●	●	●	●	●	●	●	●	●	●	●	●	●	●
Manual and part list		●	●	●	●	●	●	●	●	●	●	●	●	●	●	●	●
Door interlock		●	●	●	●	●	●	●	●	●	●	●	●	●	●	●	●
Tool/work box		●	●	●	●	●	●	●	●	●	●	●	●	●	●	●	●
Leveling blocks		●	●	●	●	●	●	●	●	●	●	●	●	●	●	●	●
Air conditioner		○	○	○	○	○	○	○	○	○	○	○	○	○	○	○	○

SMART
MACHINE TOOL

NL 1500/2000/2500/3000
CNC Turning Centers

Standard & option
specifications

Machine Dimensions

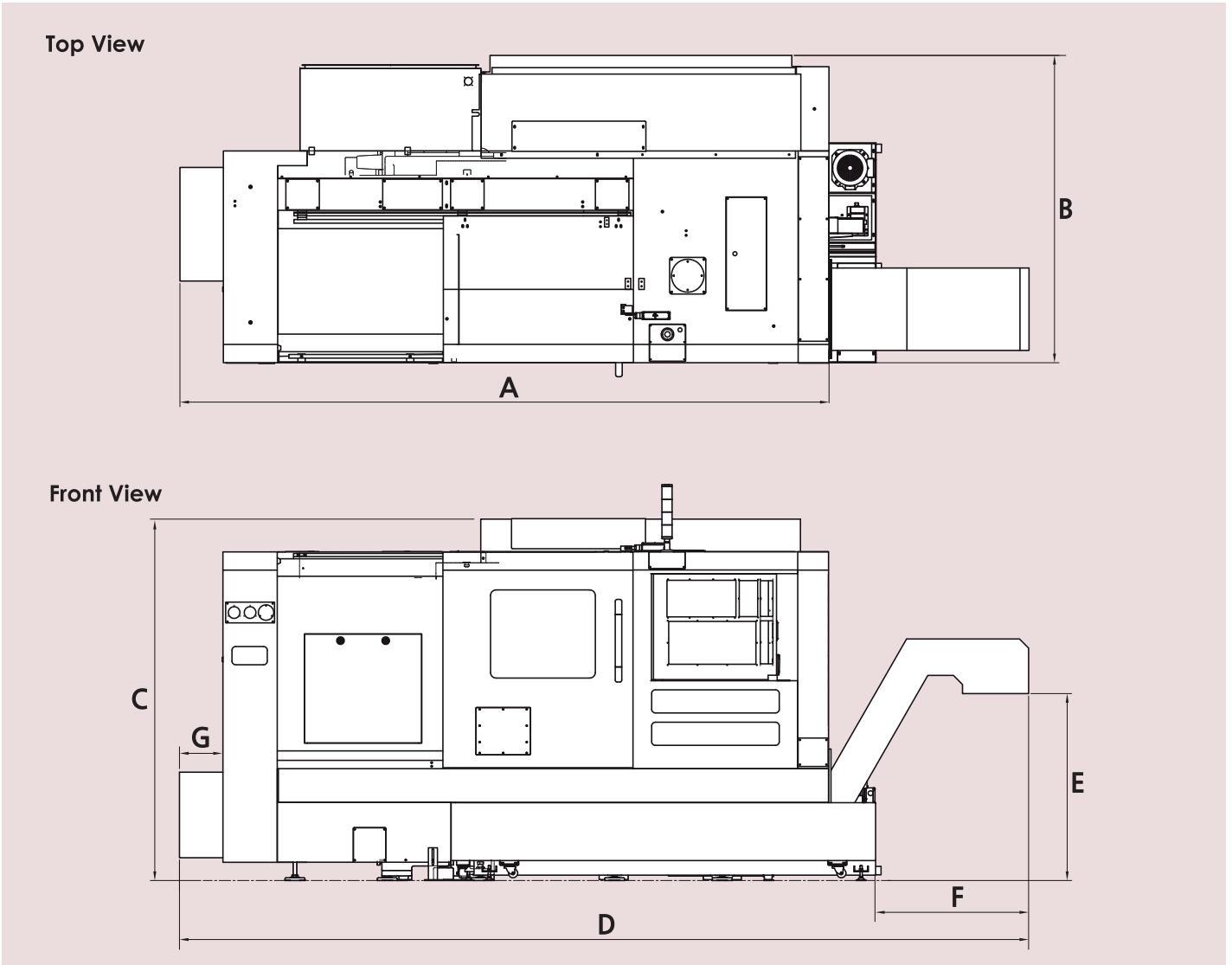

Unit : mm

Model	A (Length)	B (Width)	C (Height)	D (Length with side chip conveyor)	E (Chip conveyor height)	F (Side chip conveyor)	G (Width of motor cover)
NL 1500/M	2,743	1,551	1,902	3,776	975	783	128
NL 2000/M NL 2000B/BM	2,793			3,826			178
NL 2500S/SM	3,225	1,678	1,985	4,430	1,026	845	380(14.96)
NL 2500/M	3,584			4,690			240
NL 2500L/LM	3,985			4,996			
NL 3000B/BM	3,584			4,690			
NL 3000BL/BLM	3,985			4,996			

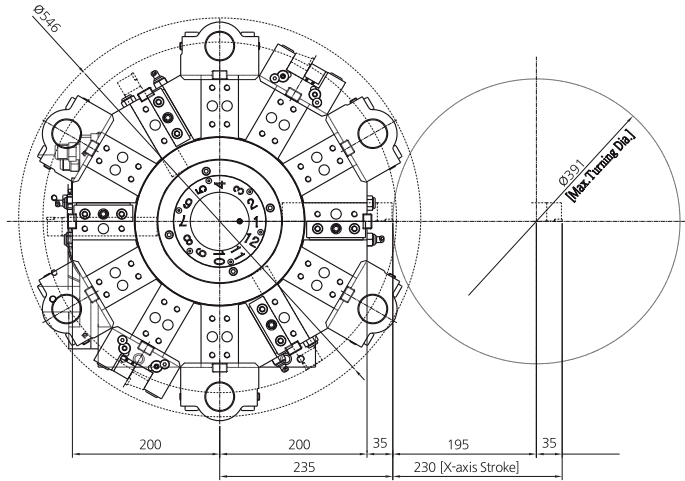

NL 1500/2000/2000B
(12 Station Std. Turret)

NL 1500M/2000M/2000BM
(BMT55 12 Station
[24 position] Mill Turret)

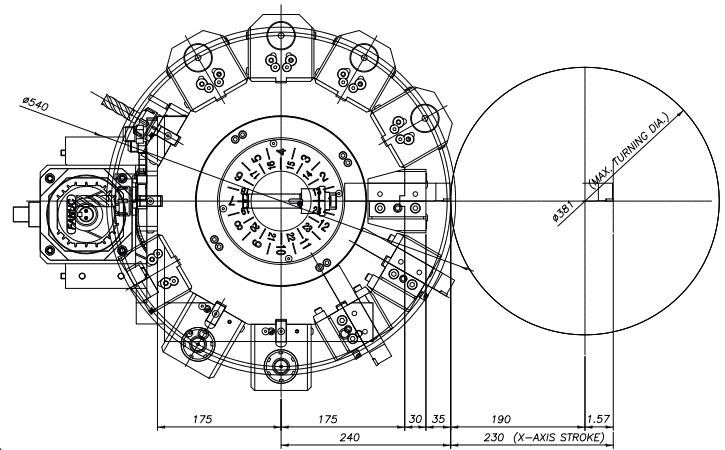

SMART
MACHINE TOOL

NL 1500/2000/2500/3000
CNC Turning Centers

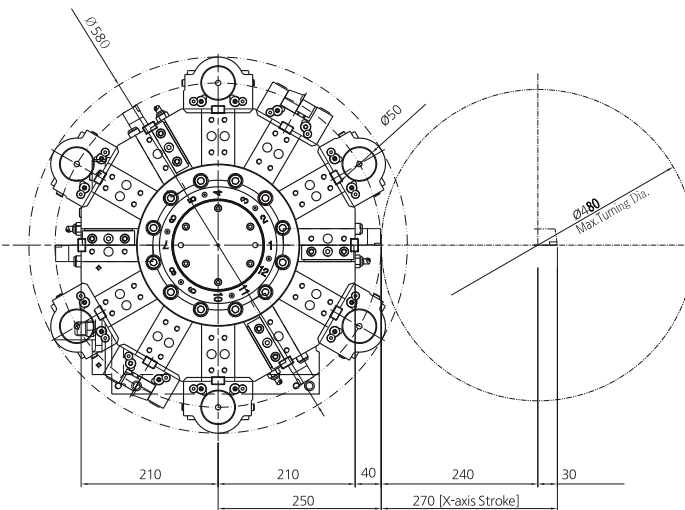

NL 2500/3000B
(12 Station Std. Turret)

NL 2500M/3000BM
(BMT65 12 Station
[24 Position] Mill Turret)

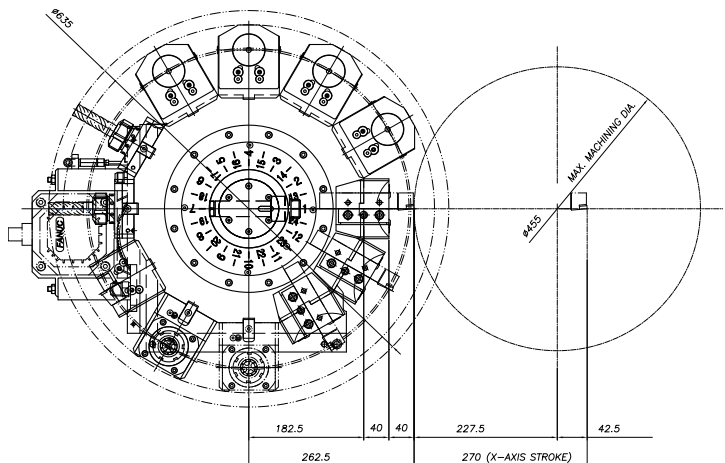

Machine dimensions &
interference

Tooling System

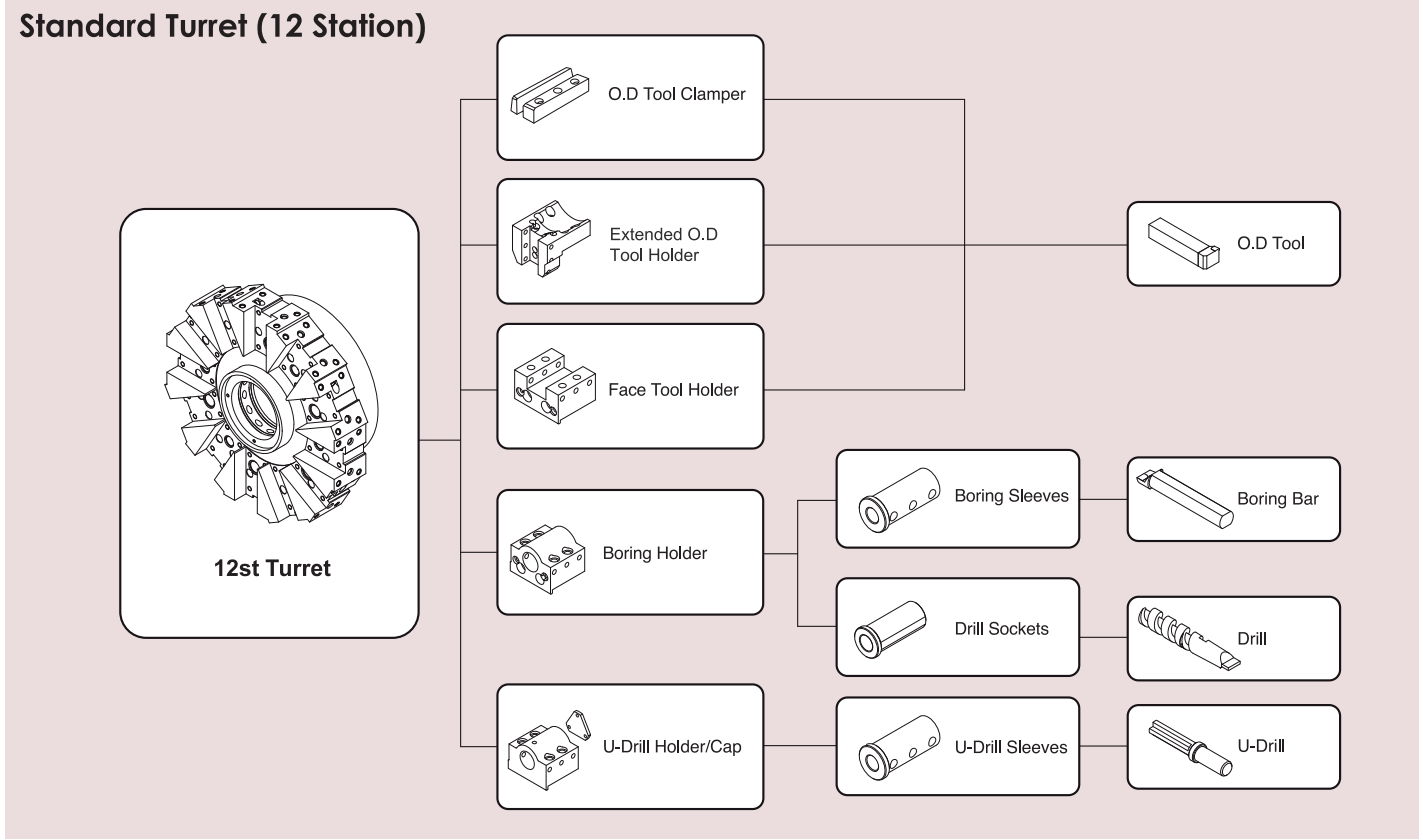

Standard Tooling Parts

Unit : mm

ITEM			NL 1500	NL 2000	NL 2000B	NL 2500	NL 3000B
Turning Holder	Extended O.D holder		-	-	1	-	-
	Facing Holder		2	2	2	2	2
Boring Holder	U-Drill holder	Single	3	3	2	3	3
	Boring holder	Single	3	3	3	3	3
Driven Holder	Axial Milling Holder		Standard	-	-	-	-
	Radial Milling Holder		Standard	-	-	-	-
Socket	Boring	Ø10	1	1	1	1	1
		Ø12	1	1	1	1	1
		Ø16	1	1	1	1	1
		Ø20	2	2	2	2	2
		Ø25	2	2	2	2	2
		Ø32	2	2	2	2	2
		Ø40	-	-	2	2	2
		Ø50	-	-	-	-	-
	Drill	MT2	1	1	-	-	-
		MT3	1	1	1	1	1
		MT4	-	-	1	1	1
		MT5	-	-	-	-	-

BMT Turret (12 Station)

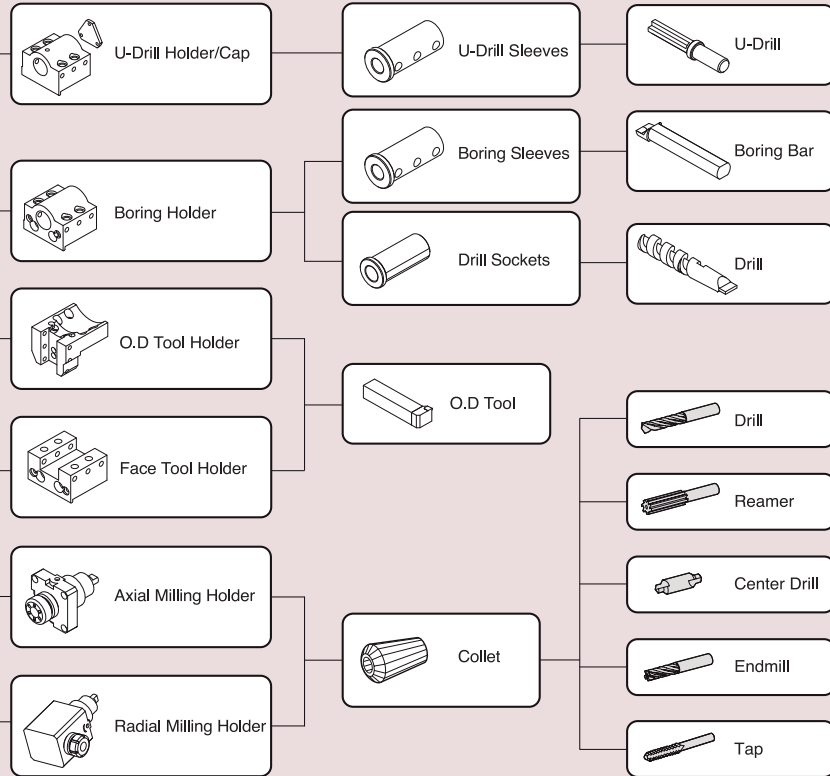
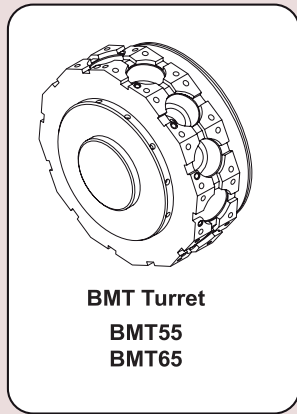

SMART
MACHINE TOOL

NL 1500/2000/2500/3000
CNC Turning Centers

Tooling system

Standard Tooling Parts

Unit : mm

ITEM			NL 1500M	NL 2000M	NL 2000BM	NL 2500M	NL 3000BM
Turning Holder	O.D Holder		3	3	3	3	3
	Facing Holder		1	1	1	1	1
Boring Holder	U-Drill Holder	Single	4	4	4	4	4
Driven Holder	Axial Milling Holder		2	2	2	2	2
	Radial Milling Holder		2	2	2	2	2
Socket	Boring	Ø10	1	1	1	1	1
		Ø12	1	1	1	1	1
		Ø16	1	1	1	1	1
		Ø20	2	2	2	2	2
		Ø25	2	2	2	2	2
		Ø32	2	2	2	2	2
		Ø40	-	-	-	2	2
		Ø50	-	-	-	-	-
	Drill	MT2	1	1	1	-	-
		MT3	1	1	1	1	1
		MT4	-	-	-	1	1
		MT5	-	-	-	-	-

Work Range

Unit : mm

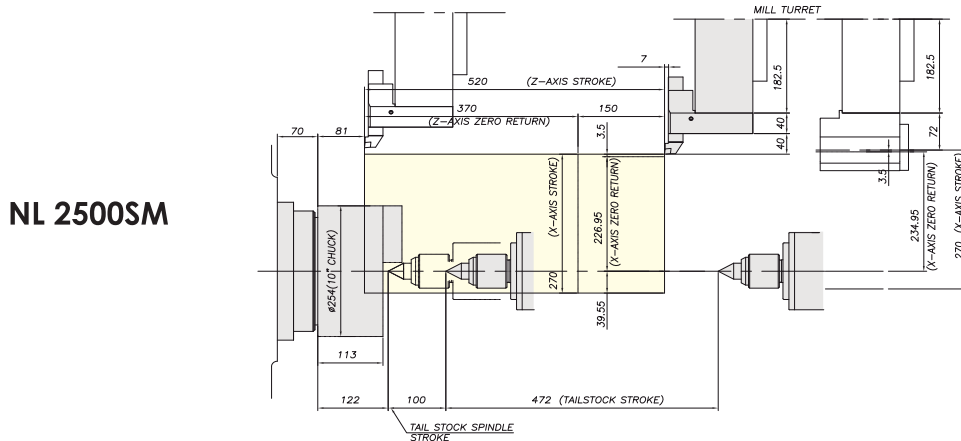
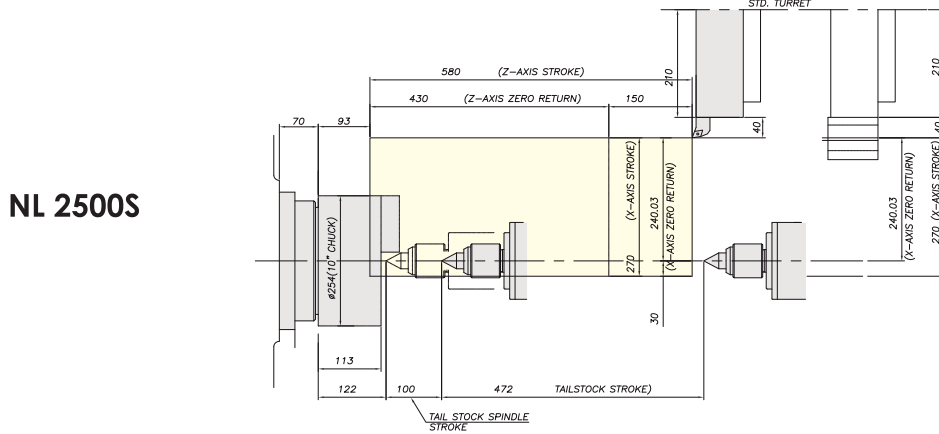
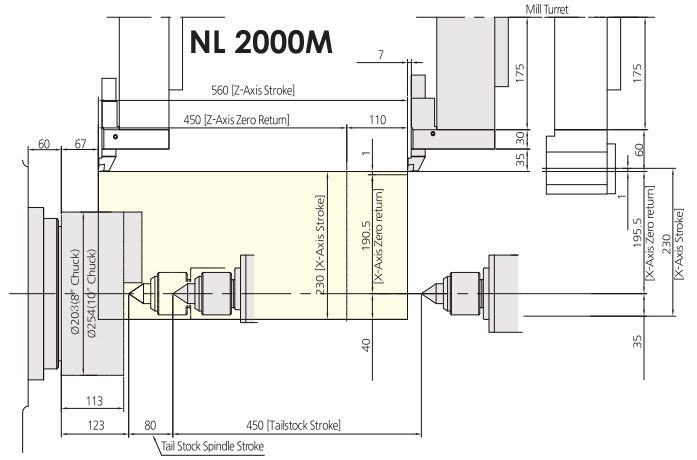
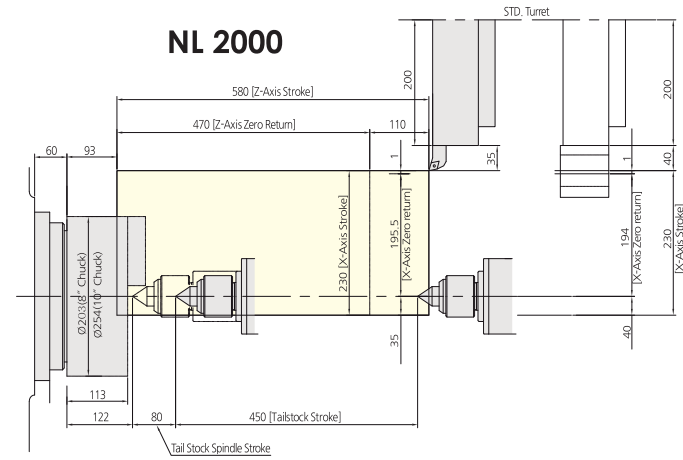
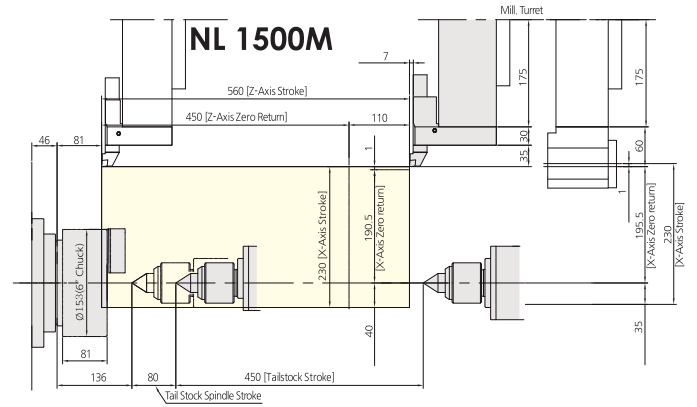
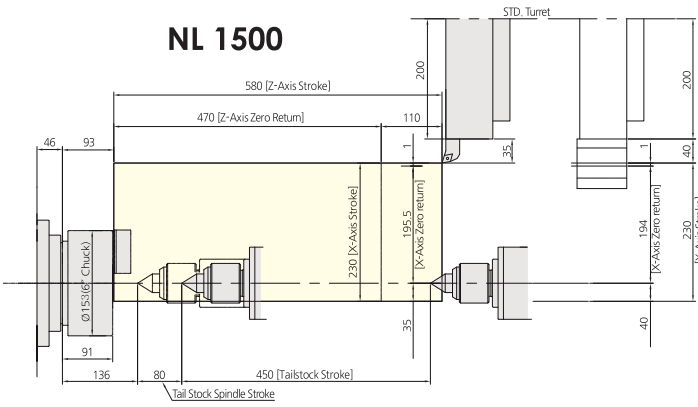

**NL 2500
NL 3000B**

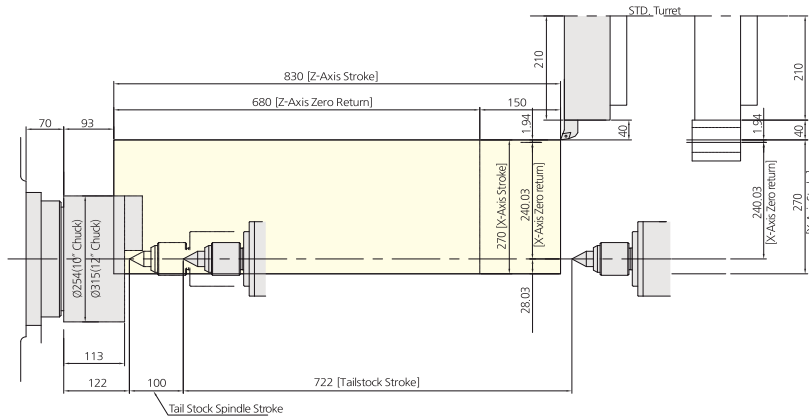

**NL 2500M
NL 3000BM**

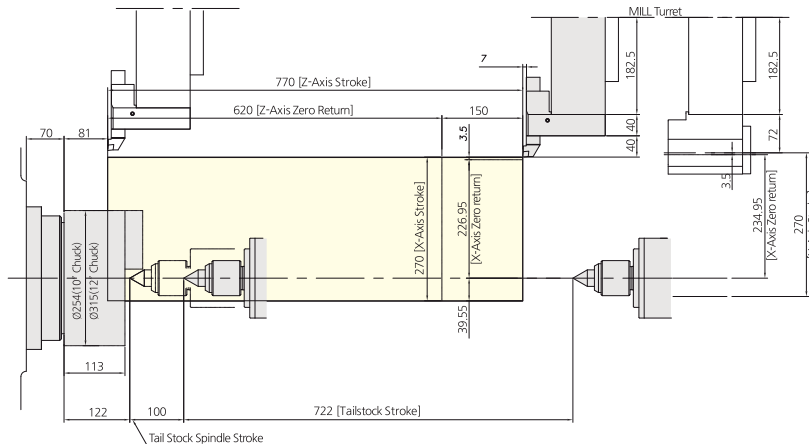

**NL 2500L
NL 3000BL**

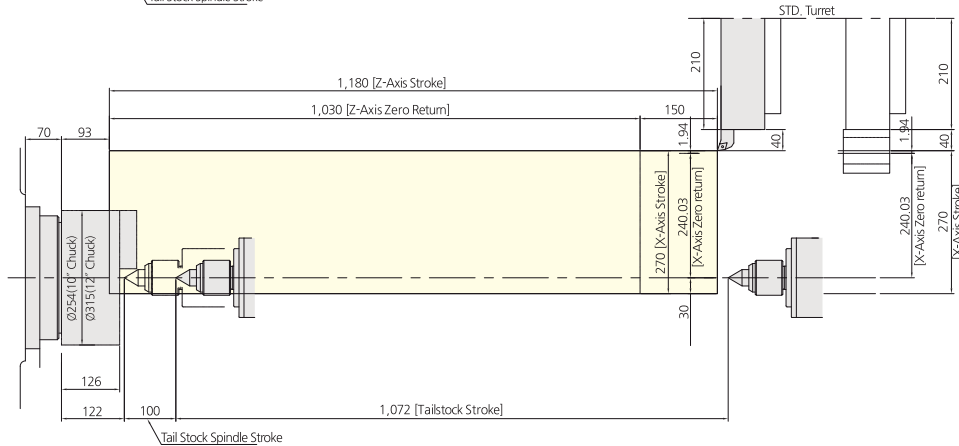

**NL 2500LM
NL 3000BLM**

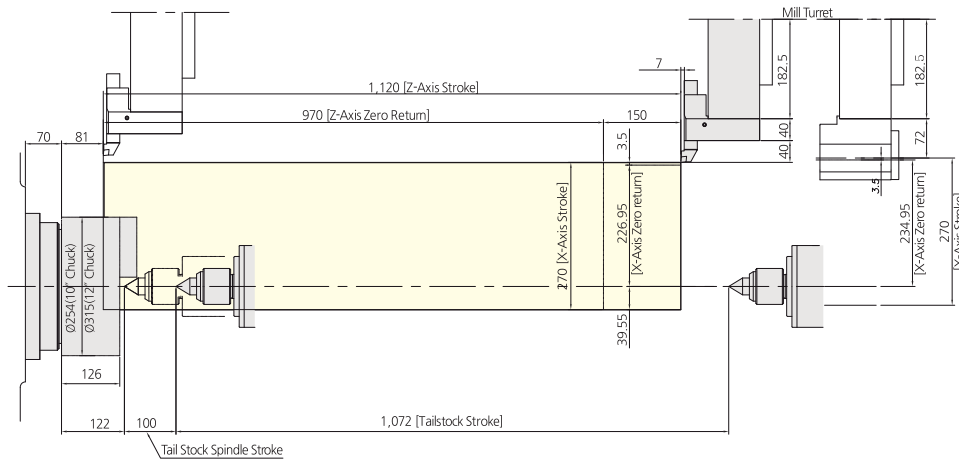

SMART
MACHINE TOOL

NL 1500/2000/2500/3000
CNC Turning Centers

Work range

Machine Specifications

DESCRIPTION			NL 1500	NL1500M	NL 2000	NL 2000M	NL 2000B	NL 2000BM
CAPACITY	Swing over the bed	mm	570					
	Swing over the cross slide	mm	370					
	Max. machining diameter	mm	391	381	391	381	391	381
	Max. machining length	mm	560	540	560	540	550	540
	Chuck size	mm	153 (6")		203 (8")		254 (10")	
	Bar working dia.	mm	52		68		82	
SPINDLE	Spindle speed	rpm	6,000		4,500		3,500	
	Spindle motor	kW	11/18.5		15/18.5			
	Spindle nose	ASA	A2-5		A2-6		A2-8	
	Spindle torque	N.m	157		336		447	
	Spindle through hole dia.	mm	61		76		91	
TRAVEL	Rapid traverse (X/Z)	m/min	24/30					
	X-axis travel	mm	230					
	Z-axis travel	mm	580	560	580	560	580	560
	Feed motor (X/Z)	kW	1.8/3	3/3	1.8/3	3/3	1.8/3	3/3
TURRET	Number of tool stations	st.	12					
	OD tool size	mm	□ 25					
	Max. boring bar size	mm	40				50	40
	Indexing time	sec	0.15					
	Milling tool holder type	-	-	BMT55	-	BMT55	-	BMT55
	Max. rotary tool spindle speed	rpm	-	5,000	-	5,000	-	5,000
	Rotary tool motor power	kW	-	3.7/5.5	-	3.7/5.5	-	3.7/5.5
TAILSTOCK	Tailstock travel	mm	450					
	Quill diameter	mm	80					
	Quill travel	mm	80					
	Taper of tailstock spindle	-	MT#4 Live center					
BED TYPE	-	45° Slant						
ELECTRIC POWER SUPPLY	kVA	30						
REQUIRED FLOOR SPACE	mm	3,140×1,56						
MACHINE WEIGHT	kg	3,800			3,900			
CONTROLLER	-	Fanuc 0i-TF Plus						

{ } : Option

DESCRIPTION			NL 2500S	NL 2500SM	NL 2500 [L]	NL 2500M [LM]	NL 3000B [BL]	NL 3000BM [BLM]	
CAPACITY	Swing over the bed	mm	700						
	Swing over the cross slide	mm	510						
	Max. machining diameter	mm	480	450	480	450	480	450	
	Max. machining length	mm	530	480	750 [1,100]	700 [1,050]	750 [1,100]	700 [1,050]	
	Chuck size	mm	254 (10")				305 (12")		
	Bar working dia.	mm	82				103		
SPINDLE	Spindle speed	rpm	3,500 {4,000}				2,800		
	Spindle motor	kW	15/18.5 {22/35}				22/35		
	Spindle nose	ASA	A2-8				A2-11		
	Spindle torque	N.m	1,256 {1,336}				1,613		
	Spindle through hole dia.	mm	91				115		
TRAVEL	Rapid traverse (X/Z)	m/min	24/30						
	X-axis travel	mm	270						
	Z-axis travel	mm	580	520	830 [1,180]	770 [1,120]	830 [1,180]	770 [1,120]	
	Feed motor (X/Z)	kW	4/4						
TURRET	Number of tool stations	st.	12						
	OD tool size	mm	□ 25						
	Max. boring bar size	mm	50						
	Indexing time	sec	0.2						
	Milling tool holder type	-	-	BMT65	-	BMT65	-	BMT65	
	Max. rotary tool spindle speed	rpm	-	5,000	-	5,000	-	5,000	
	Rotary tool motor power	kW	-	5.5/7.5	-	5.5/7.5	-	5.5/7.5	
TAILSTOCK	Tailstock travel	mm	472		722 [1,072]				
	Quill diameter	mm	110						
	Quill travel	mm	100						
	Taper of tailstock spindle	-	MT#4(Built-in)						
BED TYPE	-	45° Slant							
ELECTRIC POWER SUPPLY	kVA	35 {40}					40		
REQUIRED FLOOR SPACE	mm	3,208x1,778			3,708x1,727 [4,013x1,727]				
MACHINE WEIGHT	kg	4,700			5,700 [6,900]				
CONTROLLER	-	Fanuc 0i-TF Plus							

SMART
MACHINE TOOL

NL 1500/2000/2500/3000
CNC Turning Centers

Machine specification

NC Unit Specification/FANUC Series

● : Standard ○ : Option

	ITEM	Specification	Of-TF Plus
Controlled axis	Max. feed axes		2(3) Axis
	Feed axes		X/Z(Cs)
	Max. simultaneously controlled axis		4
	Least command increment	0.001mm / 0.0001"	●
Operation functions	Pulse handle feed	X1, X10, X100	●
	Feedrate per minute	G98	●
	Feedrate per revolution	G99	●
Interpolation functions	Linear interpolation	G01	●
	Circular interpolation	G02, G03	●
	Dwell	G04	●
	Polar coordinate interpolation	G12.1, G13.1	●
	Cylindrical interpolation	G07.1	●
	Helical interpolation		○
	Variable lead thread cutting	G34	●
	Continuous threading		●
	Reference position return	G28	●
	Reference position return check	G27	●
Feed function	Rapid traverse rate override	F0, 25%, 50%, 100%	●
	Feedrate override	0 ~ 200%	●
Spindle function	Spindle orientation		●
	Rigid tapping		●
	Arbitrary speed threading		○
Program input	Absolute/incremental programming		●
	Multiple repetitive canned cycle	G70 ~ G76	●
	Canned cycles	G90, G92, G94	●
	Inch/metric conversion	G20 / G21	●
	Program restart		●
	Retraction for rigid tapping		○
	Max. programmable dimension	±999999.999mm/±99999.9999	●
	M function	M3 digit	●
	Custom macro		●
	Canned cycle for drilling		●
	Direct drawing dimension programming		●
	Programmable data input	G10	●
	Optional block skip		●
	Workpiece coordinate system	G52 ~ G59	●
Number of registerable programs		1000EA	
Setting and display	Alarm & Operator history display		●
	Run hour and parts count display		●
	Display spindle & servo overload		●
	Self-diagnosis function		●
	Extended part program editing		●
	Display screen		15" Touch panel
Data input/output	Memory card input/output		●
	USB memory input/output		●
Editing operation	Part program storage size	2 Mbyte (5120m)	●
Manual guide <i>i</i>	Manual guide <i>i</i>		●