

SMART
MACHINE TOOL

NL 4000/5000/6000

High performance CNC Turning Centers



INAXES
CNC MACHINERY

WWW.CNC-INAXES.CZ

NL Series

NL 4000

NL 5000

NL 6000

Chuck Size

18", 21", 24"

NL Series

Designed by Smart Machine Tool engineers with many years of experience, NL Series turning centers guarantee ultra-high precision, flexible, and reliable machining performance.



		NL 4000 4000M	NL 4000L 4000LM	NL 4000XL 4000XLM	NL 4000LY
Swing Over Bed	mm	790	790	790	900
Max. Machining Length	mm	1,213 1,144	2,213 2,144	3,213 3,144	2,017
Chuck Size	mm	457 (18")	457 (18")	457 (18")	457 (18")
Bar Capacity	mm	116.5	116.5	116.5	116.5
Spindle Speed	rpm	2,000	2,000	2,000	2,000
Motor (Count./Max)	kW	30/45	30/45	30/45	30/45
Travel (X/Z/Y)	mm	340/1,300	340/2,300	340/3,300	300/2,155/150
No. of Tool Station	EA	12	12	12	12

Content

02	Product Preview
	Basic Information
06	Machine Structure
13	SMART Operation Features
	Specifications
16	Standard/Option Specifications
28	Machine Specifications



		NL 5000 5000M	NL 5000L 5000LM	NL 5000XL 5000XLM	NL 5000LY
Swing Over Bed	mm	900	900	900	900
Max. Machining Length	mm	1,155 1,119	2,155 2,119	3,155 3,119	1,992
Chuck Size	mm	533 (21")	533 (21")	533 (21")	533 (21")
Bar Capacity	mm	165.5	165.5	165.5	165.5
Spindle Speed	rpm	1,500	1,500	1,500	1,500
Motor (Count./Max)	kW	30/45	30/45	30/45	30/45
Travel (X/Z)	mm	350/1,300	350/2,300	350/1,300	300/2,155/150
No. of Tool Station	EA	12	12	12	12

NL 4000 | 5000 | 6000

- 45° slanted torque tube design bed and wide slideway for high rigidity machining
- Wide box guideways machined from one-piece casting promote heavy duty cutting
- High torque AC servo motor ensures fast indexing time and repeatability
- Excellence rapid traverse rate
- High spindle power ensures powerful cutting capability
- User-friendly operation panel design for efficient machine operation
- Various peripheral equipment and options



NL 6000S | 6000SM

Swing Over Bed	mm	1,030
Max. Machining Length	mm	750 700
Chuck Size	mm	610 (24")
Bar Capacity	mm	165.5
Spindle Speed	rpm	1,200
Motor (Count./Max)	kW	37/55
Travel (X/Z/Y)	mm	475/800
No. of Tool Station	EA	12

NL 6000 | 6000M

Swing Over Bed	mm	1,030
Max. Machining Length	mm	1,550 1,500
Chuck Size	mm	610 (24")
Bar Capacity	mm	165.5
Spindle Speed	rpm	1,200
Motor (Count./Max)	kW	37/55
Travel (X/Z/Y)	mm	475/1,600
No. of Tool Station	EA	12

NL 6000L | 6000LM

Swing Over Bed	mm	1,030
Max. Machining Length	mm	2,250 2,200
Chuck Size	mm	610 (24")
Bar Capacity	mm	165.5
Spindle Speed	rpm	1,200
Motor (Count./Max)	kW	37/55
Travel (X/Z/Y)	mm	475/2,300
No. of Tool Station	EA	12

NL 6000XL | 6000XLM

Swing Over Bed	mm	1,030
Max. Machining Length	mm	3,250 3,200
Chuck Size	mm	610 (24")
Bar Capacity	mm	165.5
Spindle Speed	rpm	1,200
Motor (Count./Max)	kW	37/55
Travel (X/Z/Y)	mm	475/3,300
No. of Tool Station	EA	12

SMART
MACHINE TOOL

NL 4000/5000/6000
CNC Turning Centers

NL Series



Machine Structure

High Rigidity Body Structure for Heavy-duty Machining



One-Piece Casting Bed

01

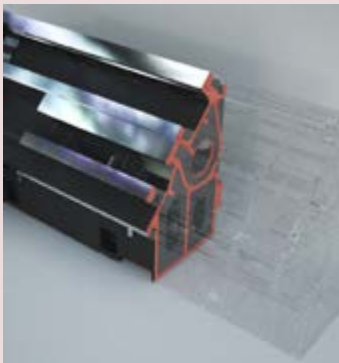

One-piece 45-degree slant bed made out of gray cast iron, which has superb vibration absorption characteristics, provides rigid foundation for all machine components. Such design endures long-term machining accuracy and consistency. In addition, 45-degree slant bed design provides operators with convenient access to the workpiece and superb chip discharge.

- Precision hand scraping of contact surfaces of all slides, headstock and tailstock with the bed ensure long-lasting machining accuracy and minimal surface wears.



Machine Structure

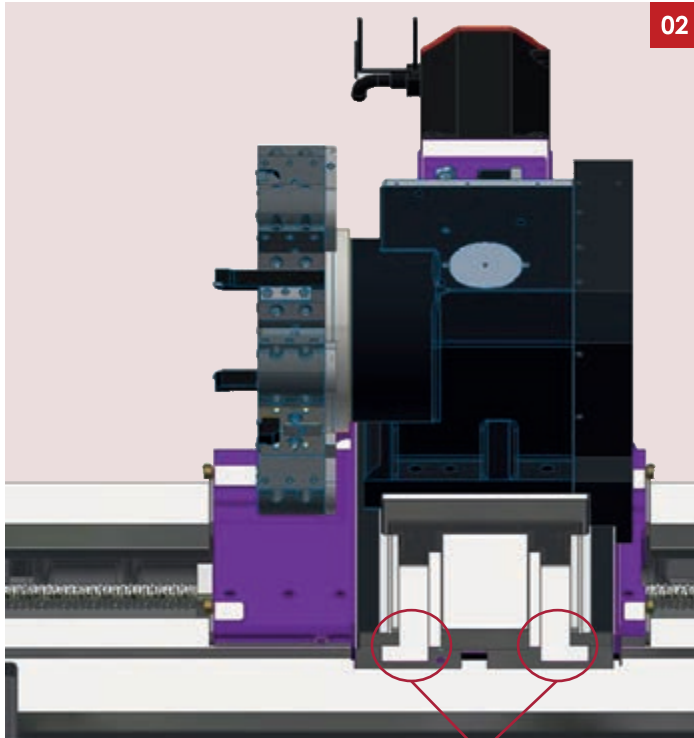

02

High Performance Feed Motor

All axes are equipped with high performance feed motor for better travel ability, excellence rapid traverse rate, smooth and precise axis movement.

Wide box guideways and Carriage

Hexahedral design and wide box guideways, machined from one piece casting, promote heavy duty machining. Induction hardened and precision ground ways ensure accurate machining for extended period of time. Wide carriage promotes less vibration and allows high precision machining.

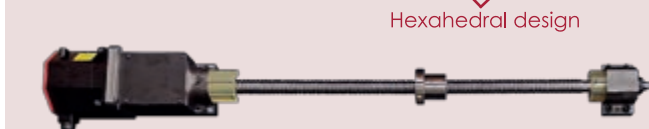

Hexahedral design

Pre-tensioned Ballscrews

All axes ballscrews are pre-tensioned, heat treated and fixed by double anchors on both ends, providing ultimate rigidity and minimal thermal growth.

Main Spindle

03

Double row cylindrical roller bearings in the front and back, coupled with angular thrust bearing, ensure high rigidity for heavy cutting and excellent surface finishes.

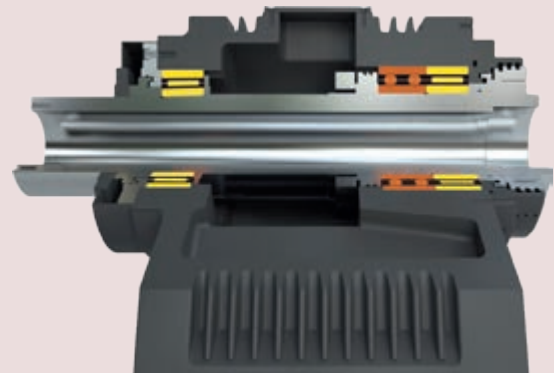

12-Station Turret

04

Large diameter 3-piece Curvic coupling for excellence rigidity and extended tool life. High torque AC servo motor driven ensure fast indexing time, excellence position and repeatability.

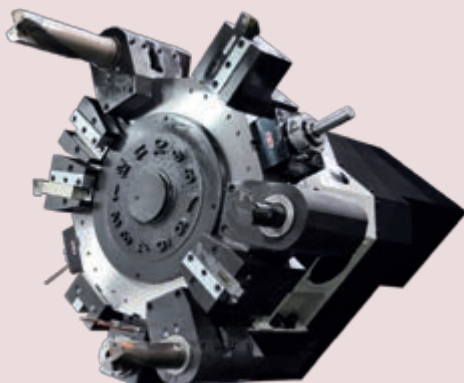

Programmable Tailstock Body & Quill

05

Wide-spaced guideways and heavy-duty tailstock body design ensure machining rigidity, and built in spindle quill design ensures higher rigidity.

NL 4000/5000

- Quill Type: **MT#5**
- Quill Dia: **Ø140 mm**
- Quill Travel: **120 mm**

NL 6000

- Quill Type: **MT#6**
- Quill Dia: **Ø180 mm**
- Quill Travel: **150 mm**



Main Spindle

High Accuracy & Performance CNC Turning Center

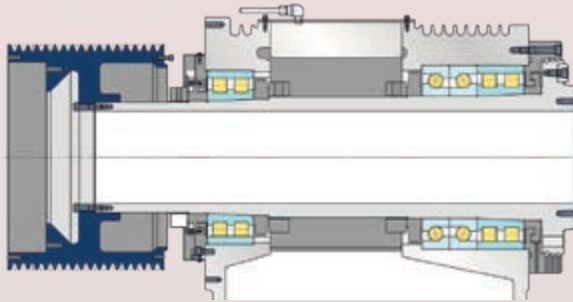

Main Spindle

Heavy-duty headstock machined from one-piece casting. Reinforced with radiator fan-like pin tube rip design dissipates heat generated by axis movements, maintaining minimal thermal expansion.

		NL 4000	NL 5000	NL 6000	NL 6000C
Chuck size	mm	457 (18")	533 (21")	610 (24")	Option
Spindle nose	ASA	A2-11	A2-15	A1-15	A1-20
Max speed	rpm	2,000	1,500	1,200	1,000
Thru hole dia.	mm	Ø132	Ø181	Ø181	Ø275
Draw tube I.D.	mm	Ø117.5	Ø166.5	Ø166.5	-

- Spindle pulley system is equipped with powerful and reliable Fanuc AC motor to ensure excellence heavy-duty cutting capability.
- V-pulley belts attach to main spindle and gearbox for high power transmission capacity, excellence grip and minimum slip between belt and pulley.
- PK type pulley belt is used to achieve low vibration, low noise and good surface roughness cutting even at high speed.

Two-Speed Gearbox

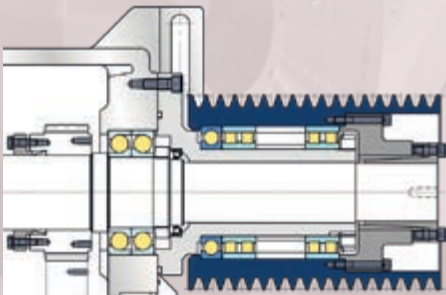

- SMART own design two-speed gearbox. The gearbox shaft is mounted with multiple sets of bearing to support high load capacity and reduce deflection.



■ Spindle Torque Diagram

NL 4000 / NL 4000M

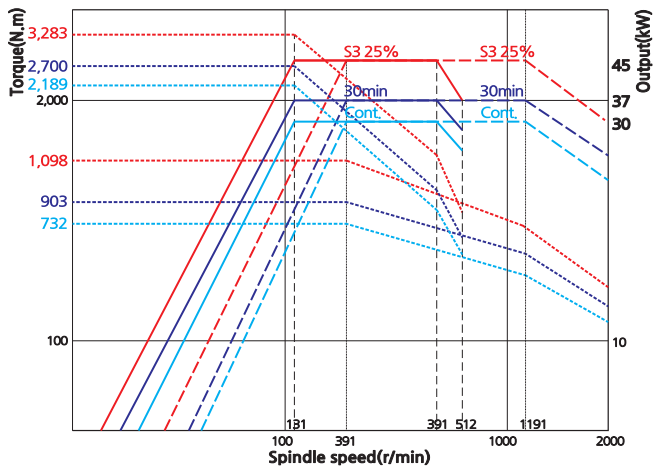

NL 4000Y

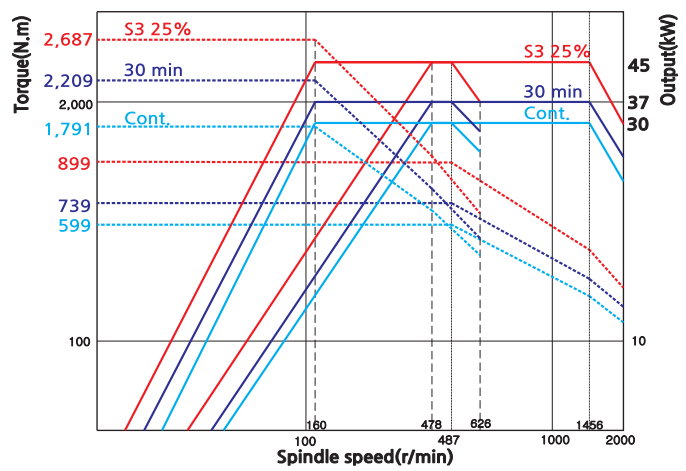

NL 5000 / NL 5000M

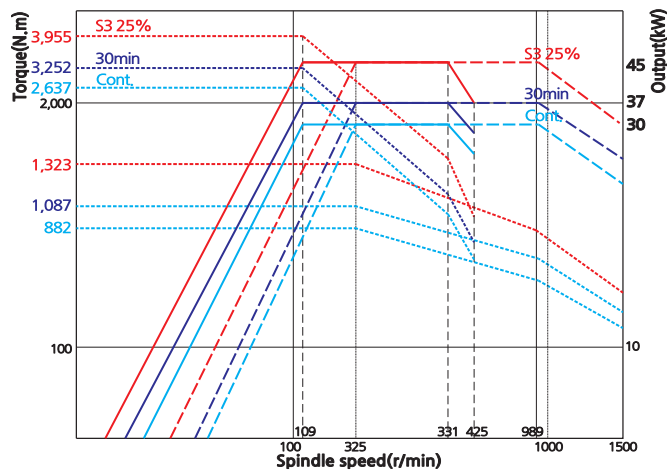

NL 5000Y

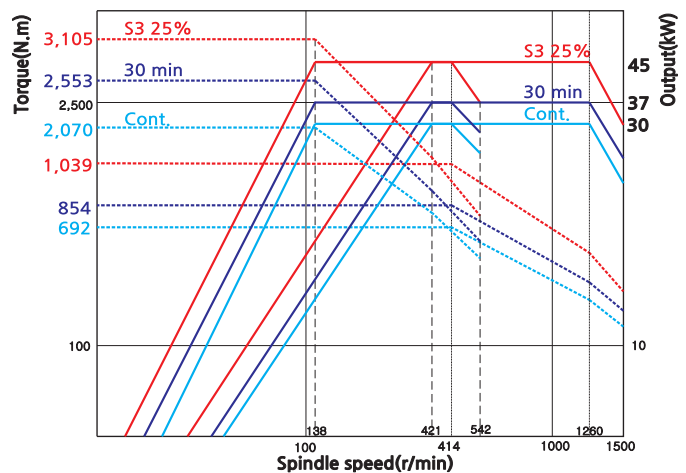

NL 6000

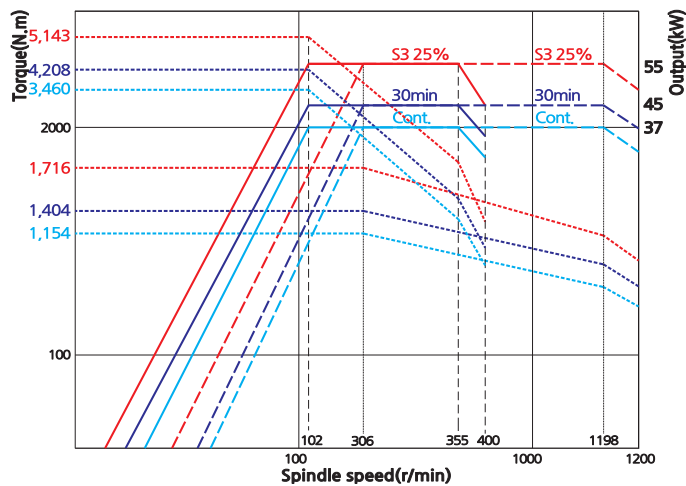

SMART
MACHINE TOOL

NL 4000/5000/6000
CNC Turning Centers

Main Spindle

Turret

Finest performance and high precision turret

Standard Turret

Heavy-duty turret driven by high torque AC servo motor for rapid rotation and repeatability. The turret design features large diameter Curvic coupling ensure accurate positioning and strong clamping power.

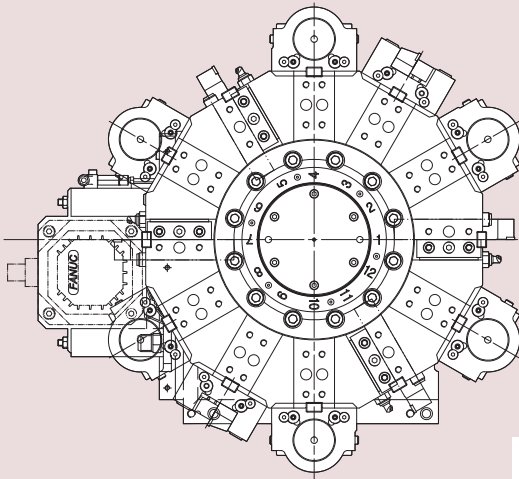

- No. of tools: **12 EA**
- Indexing time: **0.25 sec**

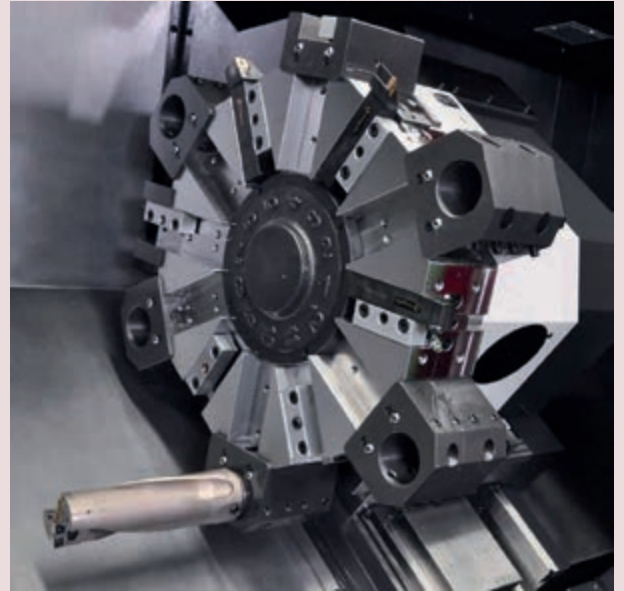

Tool Holder



Boring holder

NL 4000/5000: $\varnothing 60$ mm
NL 6000: $\varnothing 80$ mm



Bite holder

$\square 32$ mm

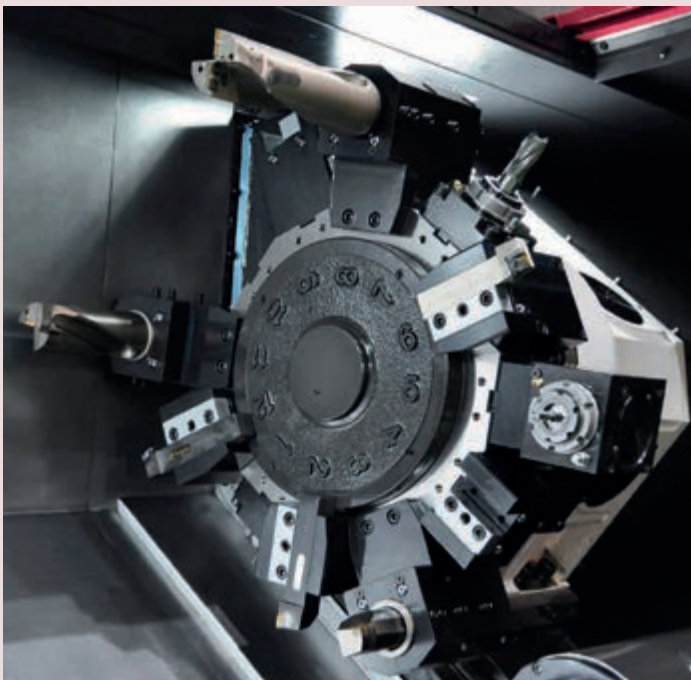

BMT Mill Turret

BMT turret is equipped with 2 separated motors for indexing and milling which improving machining performance and reducing processing time of workpiece.

Mill Tool Holder

Tool holder is mounted to BMT turret by 4 screws ensures stability, rigidity and heavy-duty machining operations.

Straight mill holder



Angular mill holder



■ Mill Tool Torque Diagram

BMT 75 (NL4000M/Y | NL5000M/Y)

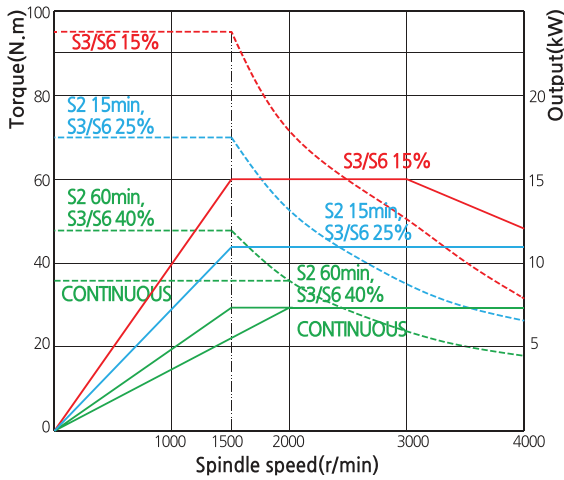

BMT 85 (NL6000)

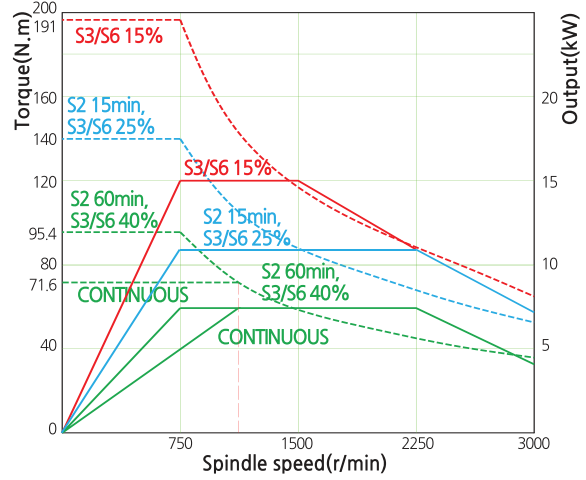

⬡ Tailstock

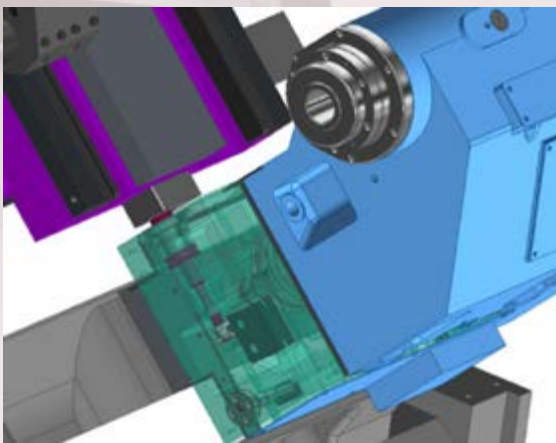

Programmable tailstock body & quill is provided as standard equipment for NL series, make easier to adjust tailstock position and minimize setup time.

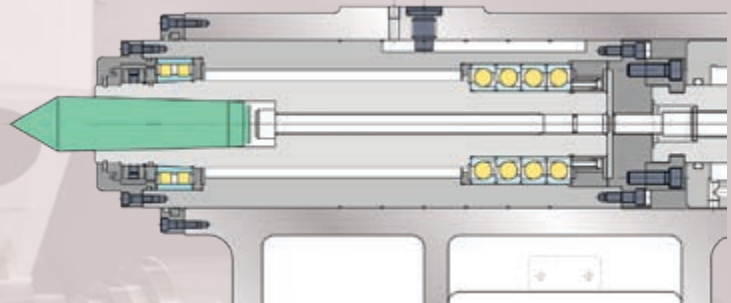

Model	Tailstock travel	Quill dia.	Quill travel	Taper	Hydraulic clamp	Hydraulic quill
	mm	mm	mm	-	kN	kN
NL 4000/M	1,165	Ø140	120	MT#5 (dead center)	72.7 (at 45 bar)	26.2 (at 45 bar)
NL 4000L/LM	2,165					
NL 4000XL/XLM	3,165					
NL 5000/M	1,165					
NL 5000L/LM	2,165					
NL5000XL/XLM	3,165					
NL 4000LY	2,077	Option				
NL 6000S/SM						
NL 6000/M	1,450					
NL 6000L/LM	2,150					
NL 6000XL/XLM	3,150	Ø180	150	MT#6 (dead center)	271 (at 60 bar)	64 (at 60 bar)

Ball screw

Ultimate rigidity ballscrew

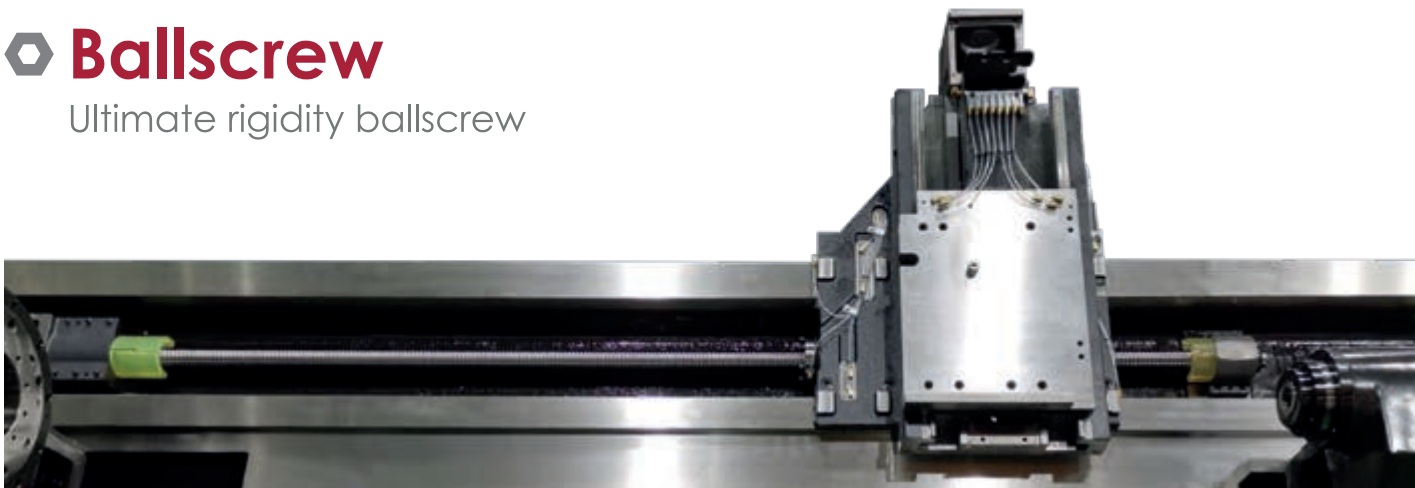

Pre-Tensioned and Double Anchored Ballscrews

Both ends of X-axis and Z-axis are fixed and preloaded with P4 high precision Angular contact ball bearing ensure precise and smooth rotation.

Machining Area

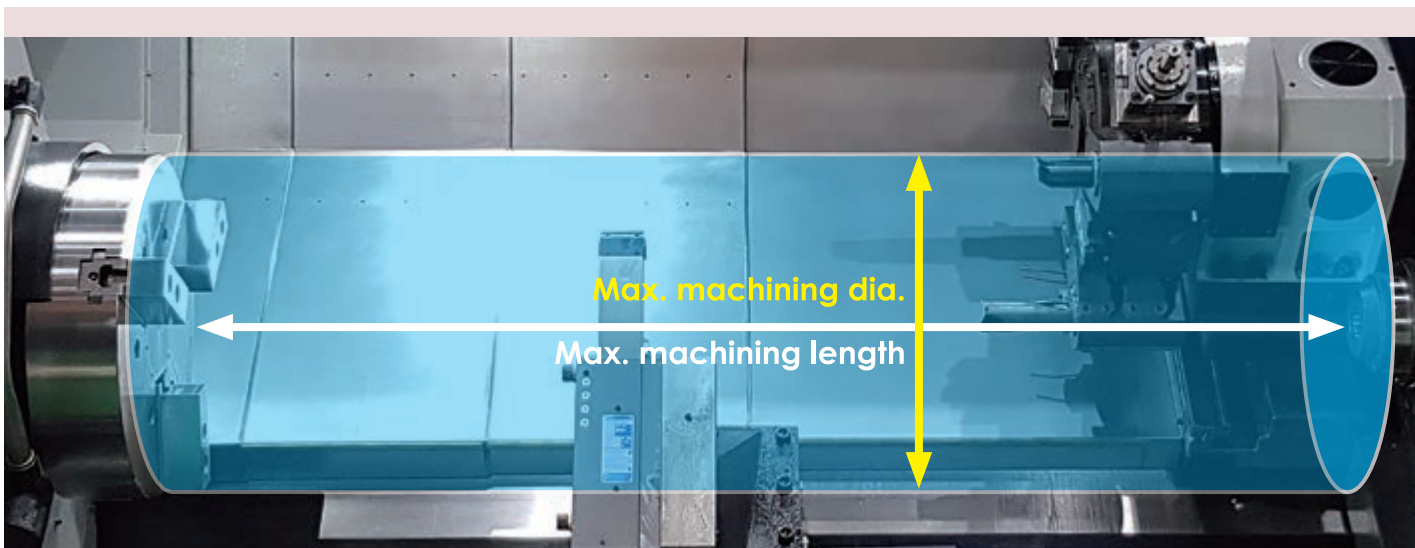

Unit : mm

Model	Max. machining dia.	Max. machining length	Bar capacity
NL 4000	Ø648	1,213	Ø116.5
NL 4000M	Ø638	1,144	
NL 4000L	Ø648	2,213	
NL 4000LM	Ø638	2,144	
NL 4000XL	Ø648	3,213	
NL4000XLM	Ø638	3,144	
NL 5000	Ø670	1,155	Ø165.5
NL 5000M	Ø650	1,119	
NL 5000L	Ø670	2,155	
NL 5000LM	Ø650	2,119	
NL5000XL	Ø670	3,155	
NL5000XLM	Ø650	3,119	

Model	Max. machining dia.	Max. machining length	Bar capacity
NL 4000LY	Ø550	2,017	Ø116.5
NL 5000LY	Ø558	1,992	Ø165.5
NL 6000S	Ø960	750	Ø165.5
NL 6000SM	Ø900	700	
NL 6000	Ø960	1,550	
NL 6000M	Ø900	1,500	
NL 6000L	Ø960	2,250	
NL 6000LM	Ø900	2,200	
NL 6000XL	Ø960	3,250	Ø165.5
NL 6000XLM	Ø900	3,200	

SMART Operation Features

Smart NL Series Turning Centers take operator convenience to the next level, offering key optional accessories as standard features of the machines.



SMART
MACHINE TOOL



BZi Sensor Std.

SMART provides BZi sensor as standard equipment, instead of position coder, for all models of NL series.

Use of BZi sensor helps reduce after sale service cost as BZi sensor does not require maintenance, unlike position coder which need regular service maintenance.

15 Inch Touchscreen Operation Panel Std.

15 inch touch type monitor with Fanuc iHMI as standard features, increase ease-of-use and improve operational efficiency.

Operator-friendly design and QWERTY keyboard layout for efficient machine operation. Protected sealed buttons to prevent letters and signs from wearing off.

Operator panel swivels up to 90 degrees, providing operators with easy access to the panel while working on the machine.

- 15 inch touchscreen
- QWERTY keyboard
- Fanuc iHMI
- Semi-permanent A/S LED lamping
- Waterproof button
- Big button size
- Replaceable button cap
- Light indicator at 100% driving status



NL 4000/5000/6000
CNC Turning Centers

Ballscrew
Machining area
SMART operation features

Metered Lubrication System Std.



Automatic lubrication dispenser reliably dispenses exact amount of lubrication, only when axes is in operation.

In the event of lubrication line failure, the system generates a warning message on CRT and stops the machine for operation safety.

High Pressure Coolant Pump Std. / Oil Skimmer Std.



Standard high pressure coolant pump sufficiently cools off the heat generated while cutting, ensuring precision machining and extended tool life, while Oil Skimmer effectively removes oil from coolant.



Belt type
oil skimmer



Easy plug-in / remove cable

Features

Manual Guide *i* **Std.**



MGI enables operators to program and simulate part programs using a conversational programming without actually running the machine.

Programmable Tailstock and Quill **Std.**



Programmable tailstock and quill make the set-up easier and faster.

Tool Presetter **Std.**



Tool presetter reduces set-up time by minimizing the need for manual skin cuts, measurement, and entering of tool offsets.

Chip Conveyor **Std.**

Equipped with wide hinged belt, worm gear reducer and torque limiter ensure stable movement and efficiently disposes of chips.



Highly Reliable Electrical Components **Std.**

Brake, power and relay circuits are integrated into one board system to minimize electrical system failure and easily to maintenance and service.

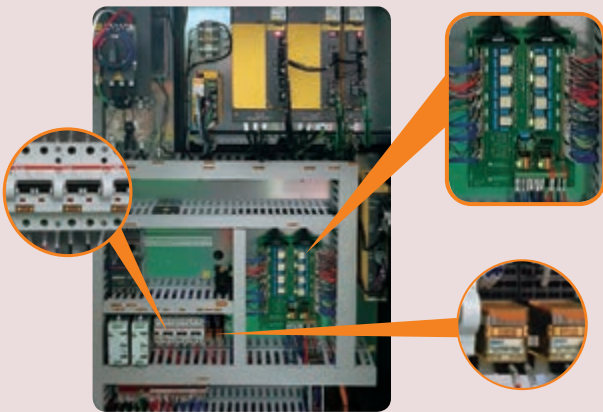

Service Oriented Sheet Metals Design **Std.**

Sheet metals are designed for easy access to the parts/units when service is needed.

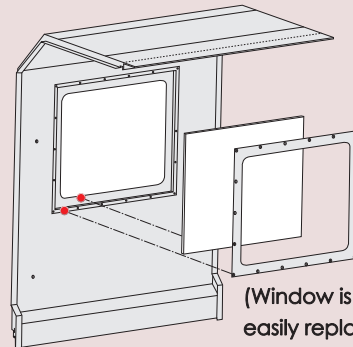

(Window is designed to be easily replaced)

CE Approved Foot Switch **Std.**

Air Gun & Coolant Gun **Opt.**

Connection-ready module design to easily add or remove accessories.





Steady Rest **Opt.**

Steady rest supports turning long workpiece and prevent workpiece from trembling.

Model	SMW-AUTOBLOK		
	SLU-X 4	SLU-X 5	SLU-X 5.1
NL 4000	O	O	X
NL 5000	O	O	O
NL 6000	X	O	O

Long Boring Bar Holder **Opt.**

Long boring bar allows high efficiency deep-hole boring operation.

Model	Long Boring Bar Holder	
	Ø80 (3")	Ø100 (4")
NL 4000	O	X
NL 5000	O	O
NL 6000	O	O

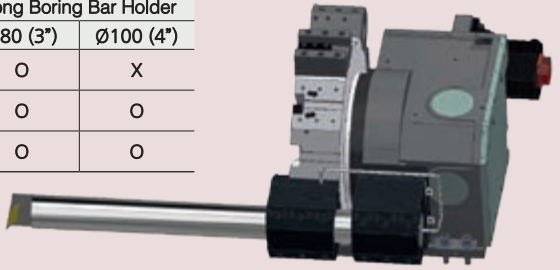

Dual Chuck **Opt.**

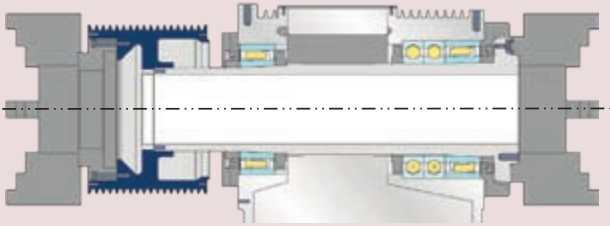

Dual chuck system helps improve machining stability for long workpiece by fix the workpiece at two positions.

Model	Front chuck				Rear chuck	
	Manual		Air		Manual	
	Size	Thru hole	Size	Thru hole	Size	Thru hole
NL 4000	14"	Ø130	-	-	14"	Ø130
NL 5000 NL 6000	18"	Ø190	18"	Ø191	18"	Ø190
NL 6000C	24"	Ø275	24"	Ø275	24"	Ø275

Re-Machining Function **Opt.**

This function allows user to easily repair damaged part.

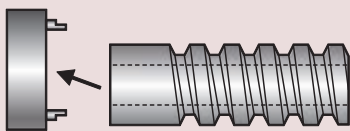

Step 1: Load the damaged part into the machine.

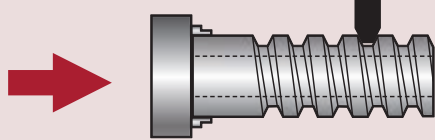

Step 2: Manually positioning the tool into the machined thread with the spindle stopped and then registering the position with the CNC.

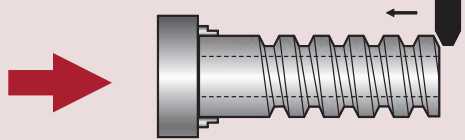

Step 3: Retract the tool, start the spindle and run the part program to re-machined the thread.

Arbitrary Speed Threading **Opt.**

Arbitrary speed threading ensures cutting tool remains coordinated with spindle speed at all time during threading. It allows user to adjust spindle speed during threading without damaging the part.

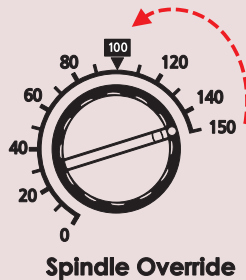
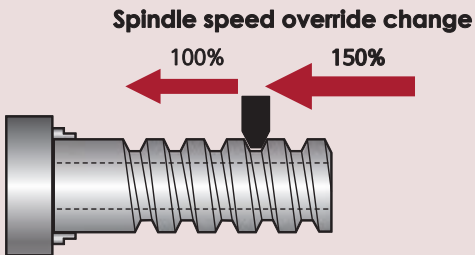

SMART MACHINE TOOL

NL 4000/5000/6000
CNC Turning Centers

SMART Operation features

Standard & Option Specifications

● : Standard ○ : Option x : Not applicable

		NL 4000					NL 5000				
		-	M	L /XL	LM/XLM	LY	-	M	L/XL	LM/XLM	LY
Spindle and Chucking											
Hydraulic 3 jaw chuck	381 mm (15")	○	○	○	○	○	X	X	X	X	X
	457 mm (18")	●	●	●	●	●	○	○	○	○	○
	533 mm (21")	X	X	X	X	X	●	●	●	●	●
	610 mm (24")	X	X	X	X	X	○	○	○	○	X
Dual pressure chucking		○	○	○	○	○	○	○	○	○	○
Chuck clamp foot switch		●	●	●	●	●	●	●	●	●	●
Chuck clamp confirmation		●	●	●	●	●	●	●	●	●	●
Dual chuck		○	○	○	○	○	○	○	○	○	○
2 step gearbox		●	●	●	●	●	●	●	●	●	●
Jaw											
Soft jaw	3 set	●	●	●	●	●	●	●	●	●	●
Hard jaw	1 set	●	●	●	●	●	●	●	●	●	●
Special chuck		○	○	○	○	○	○	○	○	○	○
Turret											
Long boring bar holder	Ø80mm	○	○	○	○	○	○	○	○	○	○
	Ø100mm	X	X	X	X	X	○	○	○	○	○
Steady Rest											
SLU-X 4	Ø30~Ø245 mm	○	○	○	○	○	○	○	○	○	○
SLU-X 5	Ø45~Ø310 mm	○	○	○	○	○	○	○	○	○	○
SLU-X 5.1	Ø85~Ø350 mm	X	X	X	X	○	○	○	○	○	○
Tailstock											
Programmable tailstock		●	●	●	●	●	●	●	●	●	●
Tailstock taper	MT#5	●	●	●	●	●	●	●	●	●	●
Built-in live center		●	●	●	●	●	●	●	●	●	●
Tailstock in-out foot switch		●	●	●	●	●	●	●	●	●	●
Coolant											
High pressure coolant pump	10 bar (140 psi)	●	●	●	●	●	●	●	●	●	●
	20 bar (290psi)	○	○	○	○	○	○	○	○	○	○
Oil skimmer		●	●	●	●	●	●	●	●	●	●
Coolant chiller		○	○	○	○	○	○	○	○	○	○
Coolant filtration system	25µm filter	○	○	○	○	○	○	○	○	○	○
Chuck coolant		○	○	○	○	○	○	○	○	○	○
Shower coolant		○	○	○	○	○	○	○	○	○	○
Coolant gun		○	○	○	○	○	○	○	○	○	○
Chip Disposal											
Chip conveyor		●	●	●	●	●	●	●	●	●	●
Chip bucket		○	○	○	○	○	○	○	○	○	○
Air gun		○	○	○	○	○	○	○	○	○	○
Air blower		○	○	○	○	○	○	○	○	○	○
Mist collector		○	○	○	○	○	○	○	○	○	○
Measurement & Automatic Operation											
Tool presetter		●	●	●	●	●	●	●	●	●	●
Auto door		○	○	○	○	○	○	○	○	○	○
Others											
Operation status light tower		●	●	●	●	●	●	●	●	●	●
Work light (LED lamp)		●	●	●	●	●	●	●	●	●	●
Manual and part list		●	●	●	●	●	●	●	●	●	●
Door interlock		●	●	●	●	●	●	●	●	●	●
Tool/work box		●	●	●	●	●	●	●	●	●	●
Leveling blocks		●	●	●	●	●	●	●	●	●	●

Standard & Option Specifications

● : Standard ○ : Option X : Not applicable

		NL 6000								
		S	SM	-	M	L	LM	XL	XLM	C
Spindle and Chucking										
Hydraulic 3 jaw chuck	610 mm (24")	●	●	●	●	●	●	●	●	X
	813 mm (32")	○	○	○	○	○	○	○	○	X
Dual pressure chucking		○	○	○	○	○	○	○	○	○
Chuck clamp foot switch		●	●	●	●	●	●	●	●	●
Chuck clamp confirmation		●	●	●	●	●	●	●	●	●
Dual chuck		○	○	○	○	○	○	○	○	○
2 step gearbox		●	●	●	●	●	●	●	●	●
Jaw										
Soft jaw	3 set	●	●	●	●	●	●	●	●	○
Hard jaw	1 set	●	●	●	●	●	●	●	●	○
Special chuck		○	○	○	○	○	○	○	○	○
Turret										
Long boring bar holder	Ø80mm	○	○	○	○	○	○	○	○	○
	Ø100mm	○	○	○	○	○	○	○	○	○
Steady Rest										
SLU-X 5	Ø45~Ø310 mm	○	○	○	○	○	○	○	○	○
SLU-X 5.1	Ø85~Ø350 mm	○	○	○	○	○	○	○	○	○
K6	Ø135~Ø460 mm	○	○	○	○	○	○	○	○	○
Tailstock										
Programmable tailstock		○	○	●	●	●	●	●	●	●
Tailstock taper	MT#6	○	○	●	●	●	●	●	●	●
Built-in live center		○	○	●	●	●	●	●	●	●
Tailstock in-out foot switch		○	○	●	●	●	●	●	●	●
Coolant										
High pressure coolant pump	10 bar (140 psi)	●	●	●	●	●	●	●	●	●
	20 bar (290psi)	○	○	○	○	○	○	○	○	○
Oil skimmer		●	●	●	●	●	●	●	●	●
Coolant chiller		○	○	○	○	○	○	○	○	○
Coolant filtration system	25µm filter	○	○	○	○	○	○	○	○	○
Chuck coolant		○	○	○	○	○	○	○	○	○
Shower coolant		○	○	○	○	○	○	○	○	○
Coolant gun		○	○	○	○	○	○	○	○	○
Chip Disposal										
Chip conveyor		●	●	●	●	●	●	●	●	●
Chip bucket		○	○	○	○	○	○	○	○	○
Air gun		○	○	○	○	○	○	○	○	○
Air blower		○	○	○	○	○	○	○	○	○
Mist collector		○	○	○	○	○	○	○	○	○
Measurement & Automatic Operation										
Tool presetter		●	●	●	●	●	●	●	●	●
Auto door		○	○	○	○	○	○	○	○	○
Others										
Operation status light tower		●	●	●	●	●	●	●	●	●
Work light (LED lamp)		●	●	●	●	●	●	●	●	●
Manual and part list		●	●	●	●	●	●	●	●	●
Door interlock		●	●	●	●	●	●	●	●	●
Tool/work box		●	●	●	●	●	●	●	●	●
Leveling blocks		●	●	●	●	●	●	●	●	●

SMART
MACHINE TOOL

NL 4000/5000/6000
CNC Turning Centers

Standard & Option Specifications

Machine Dimensions

Top View

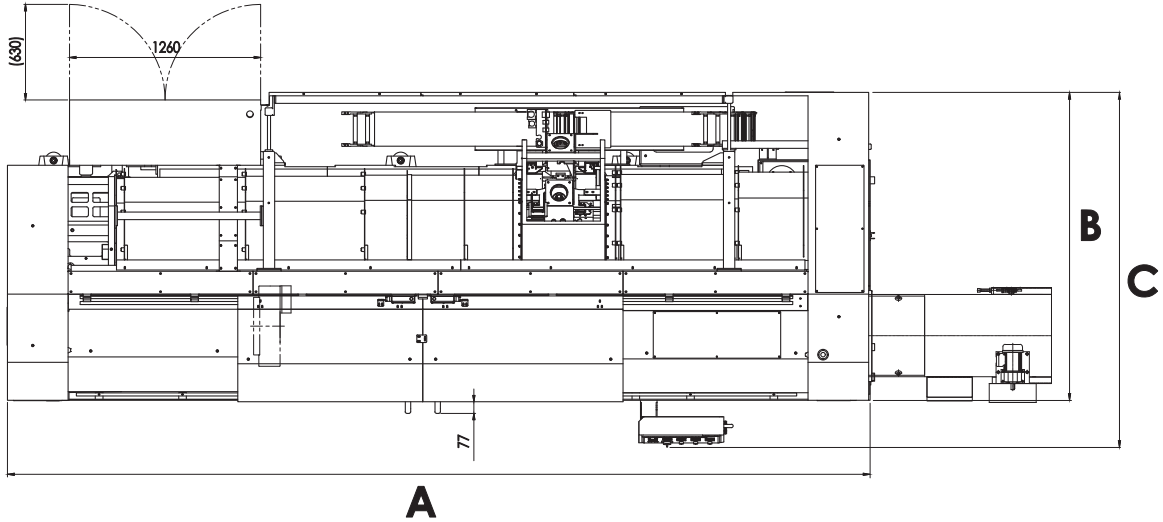

Front View

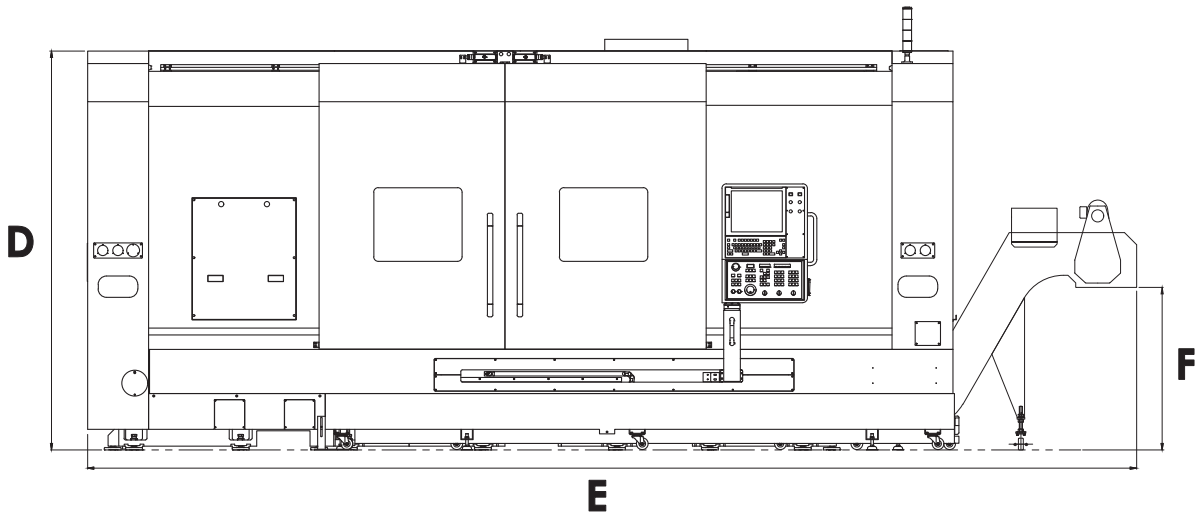

Unit : mm

Model	A (Length)	B (Width)	C (Width with controller)	D (Height)	E (Length with side chip conveyor)	F (Chip conveyor height)
NL 4000/M	4,410	1,940	-	2,268	5,616	1,063
NL 4000L/LM	5,680	1,940	2,239		6,886	1,066
NL 4000XL/XLM	6,680	2,010	2,309		7,885	
NL 5000/M	4,410	1,940	-		5,616	1,063
NL 5000L/LM	5,680	1,940	2,239		6,886	1,066
NL 5000XL/XLM	6,680	2,010	2,309		7,885	
NL 4000LY	5,680	2,040	2,339	2,618	6,886	1,066
NL 5000LY						
NL 6000S/SM	4,335	2,312	-	2,300	5,561	1,058
NL 6000/M	5,135		6,364			
NL 6000L/LM	5,948		2,611		7,174	
NL 6000XL/XLM	7,043		2,681		8,269	

**NL 4000/L/XL
(12 Station Std. Turret)**

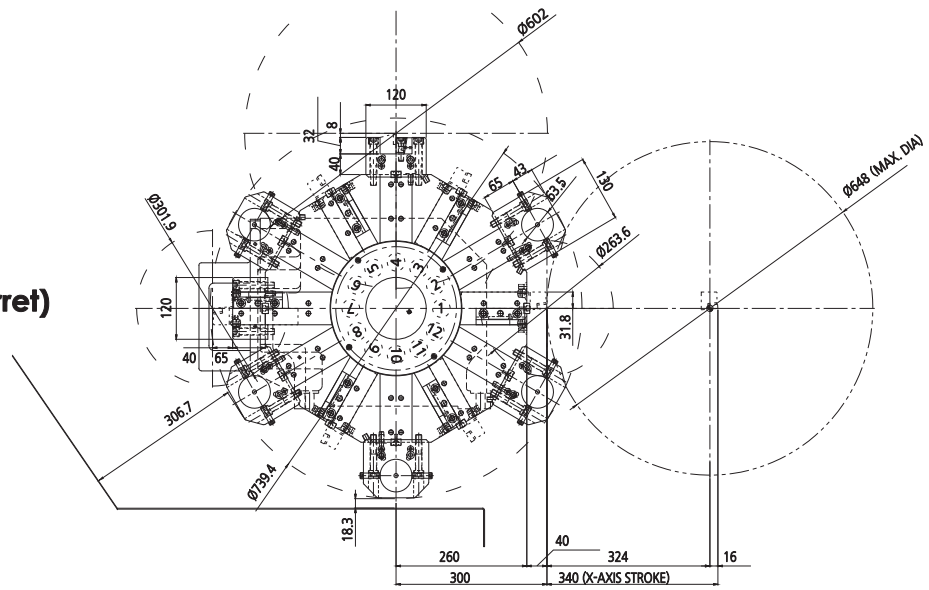

**NL 4000M/LM/XLM
(BMT75 12 Station
Mill Turret)**

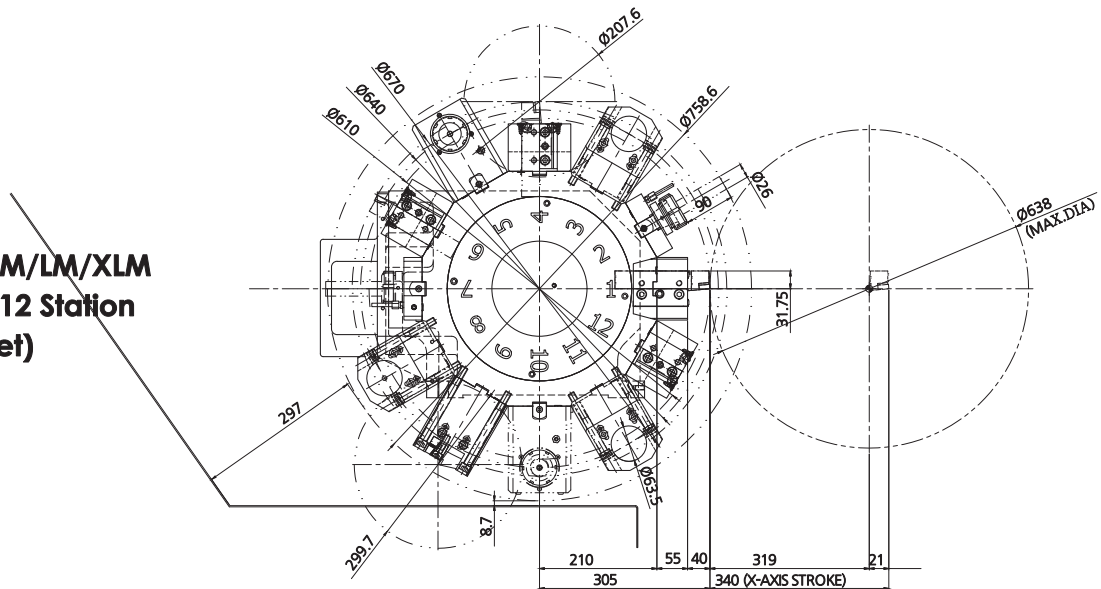

**NL 5000/L/XL
(12 Station Std. Turret)**

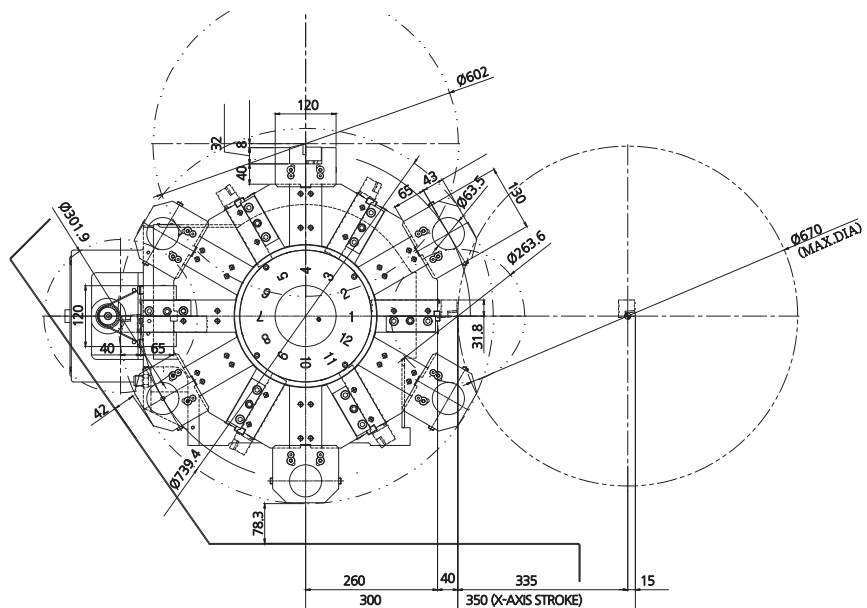

SMART
MACHINE TOOL

NL 4000/5000/6000
CNC Turning Centers

Machine dimension
Interference

Work Range

Unit : mm

NL 4000L/XL

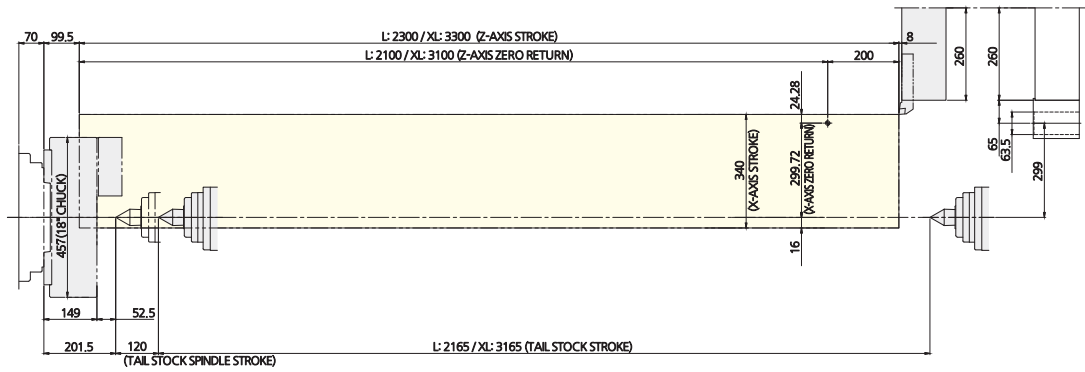

NL 4000LM/XLM

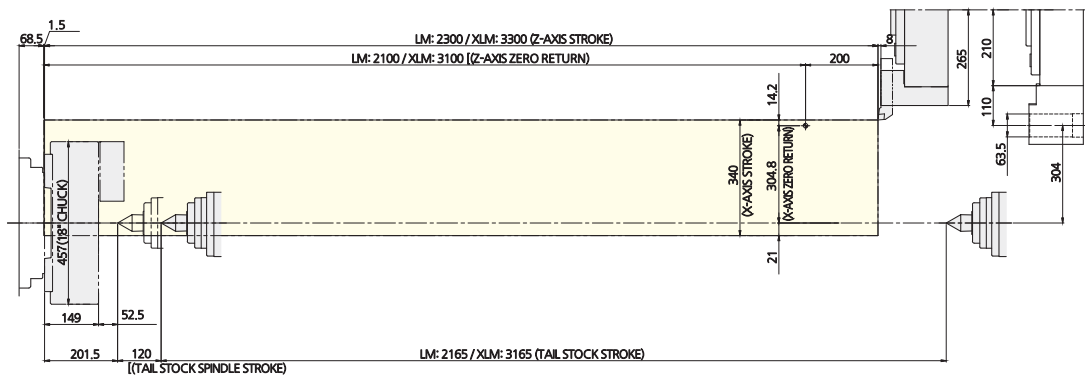

NL 4000LY

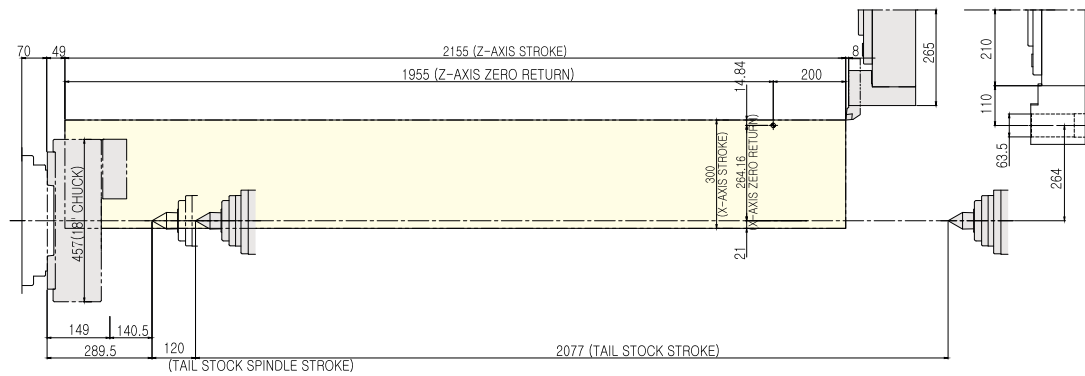

NL 5000

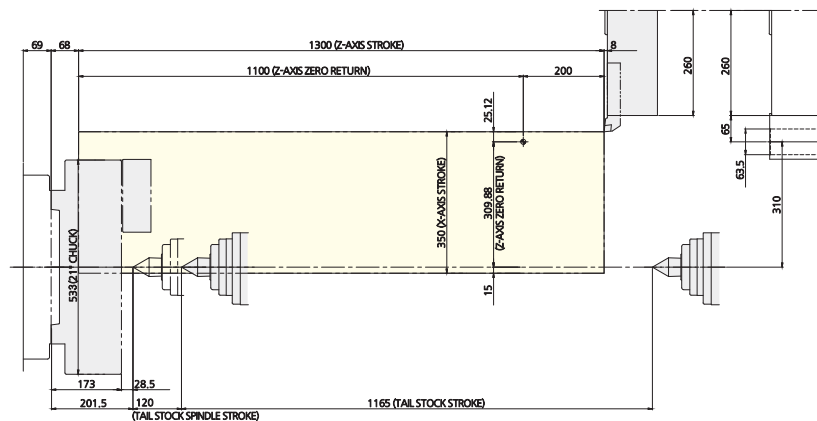

NL 5000M

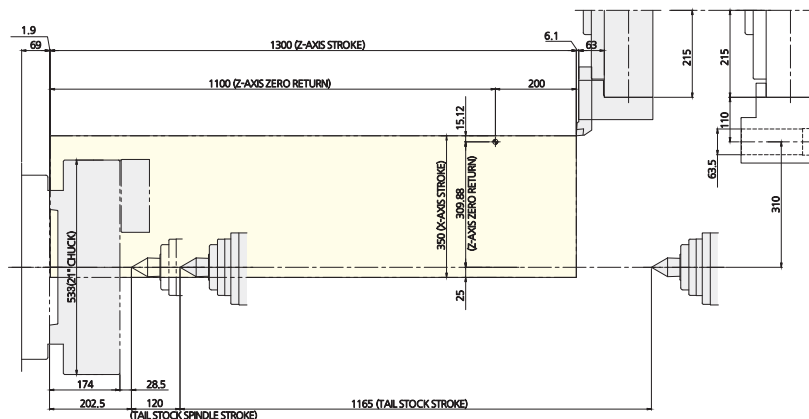

NL 5000L/XL

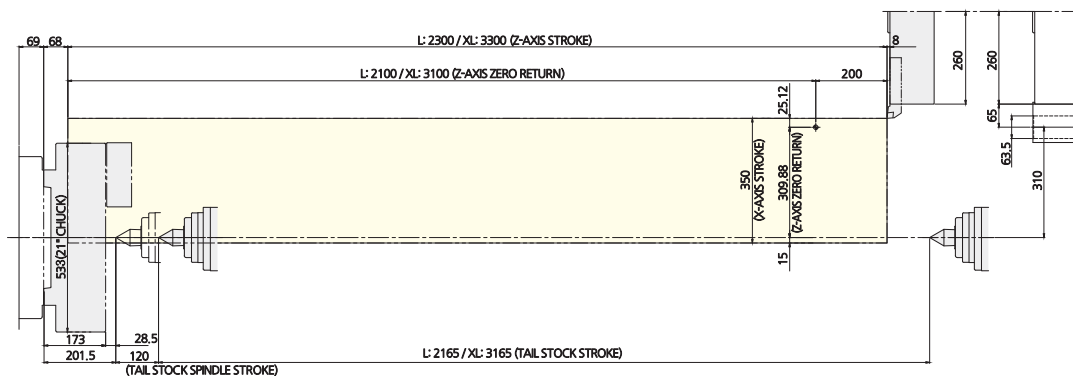

NL 5000LM/XLM

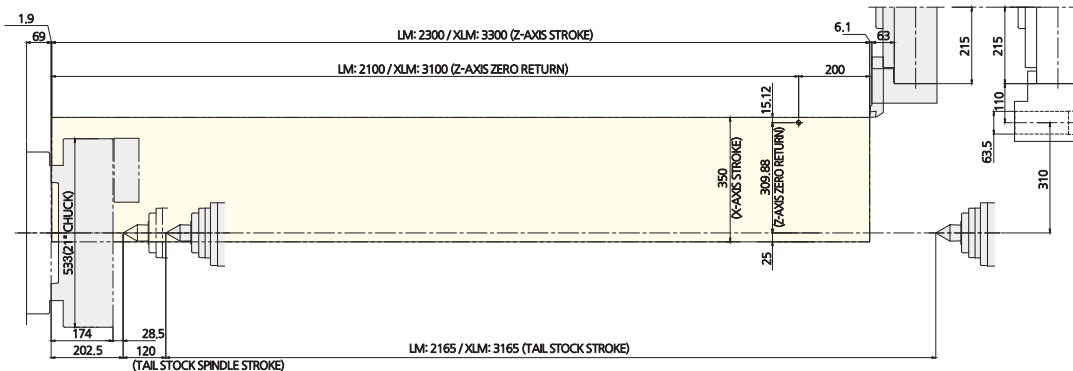

NL 5000LY

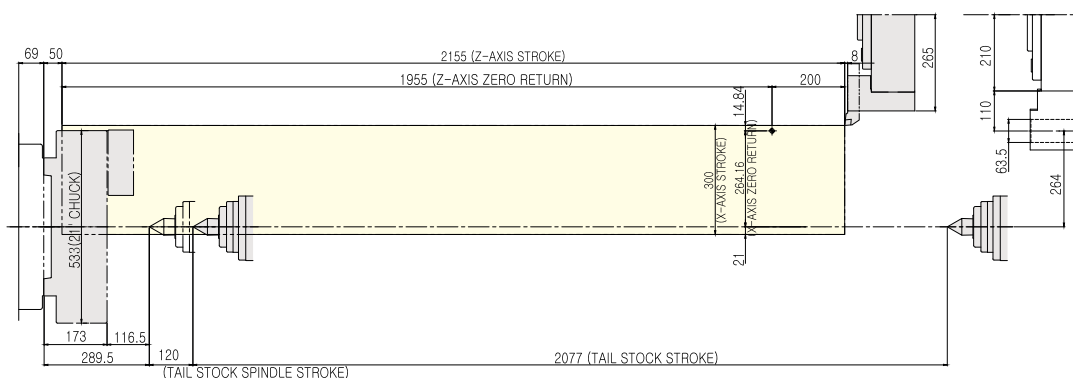

SMART
MACHINE TOOL

NL 4000 / 5000 / 6000
CNC Turning Centers

Work Range

Work Range

Unit : mm

NL 6000S

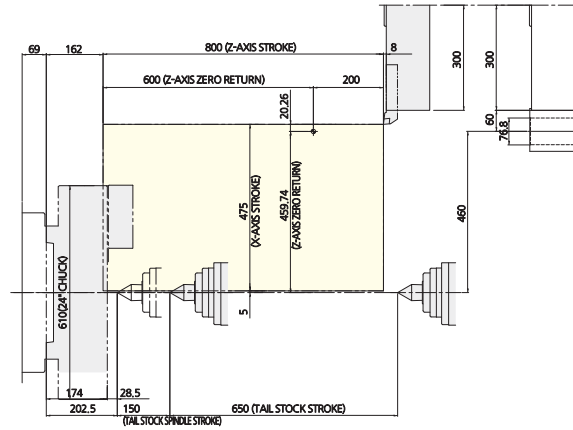

NL 6000SM

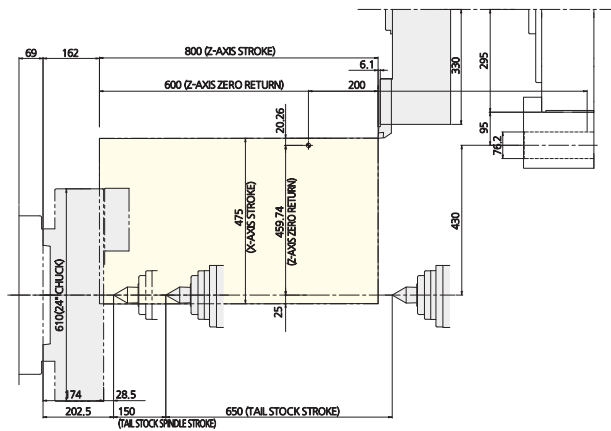

NL 6000

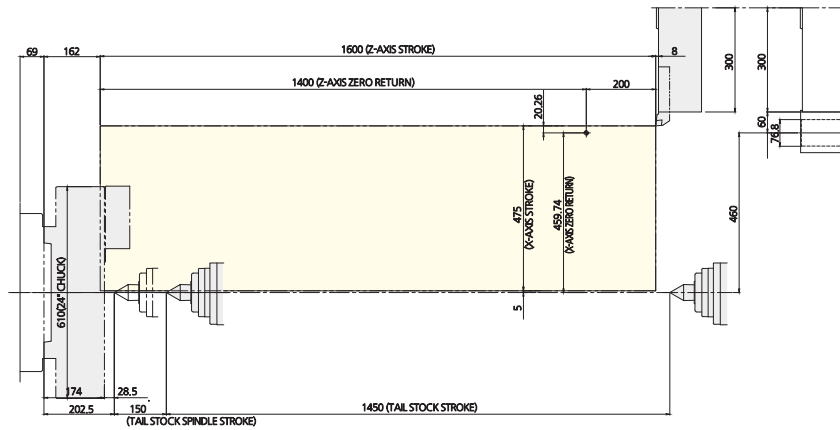

NL 6000M

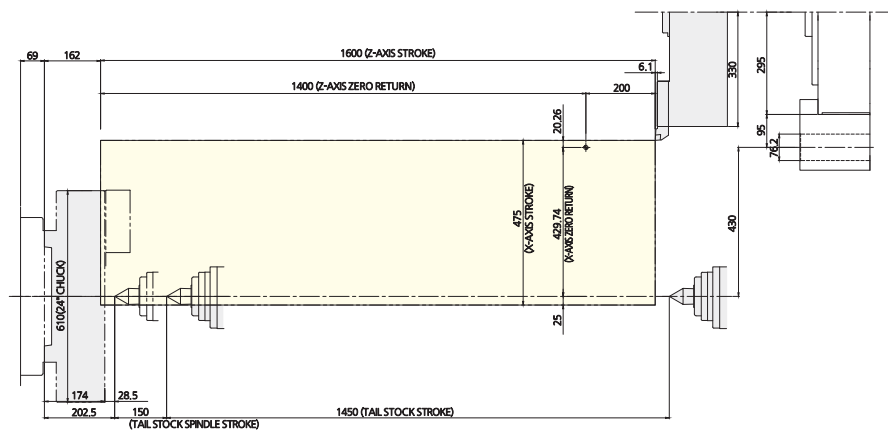

NL 6000L

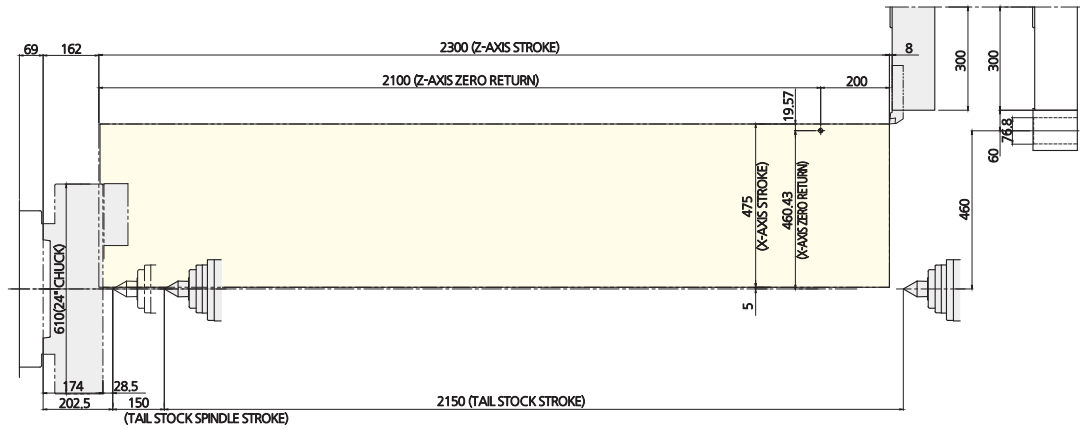

NL 6000LM

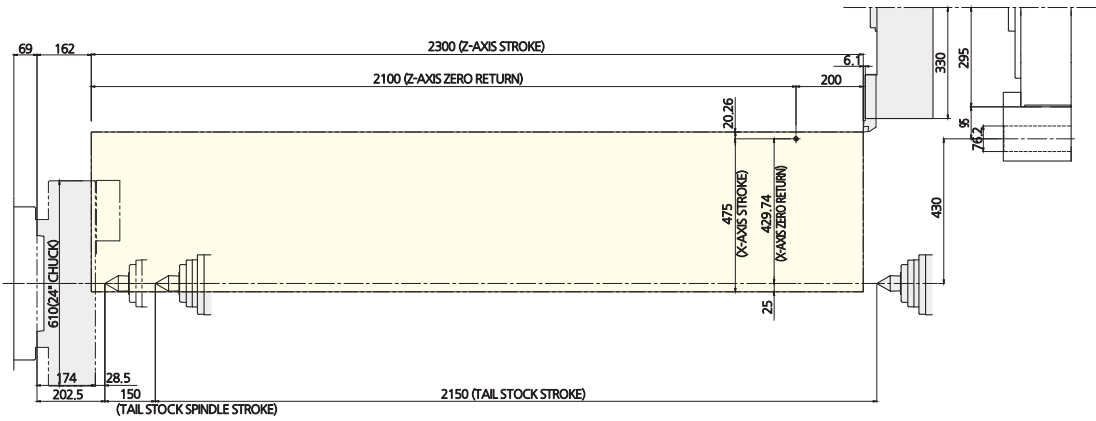

NL 6000XL

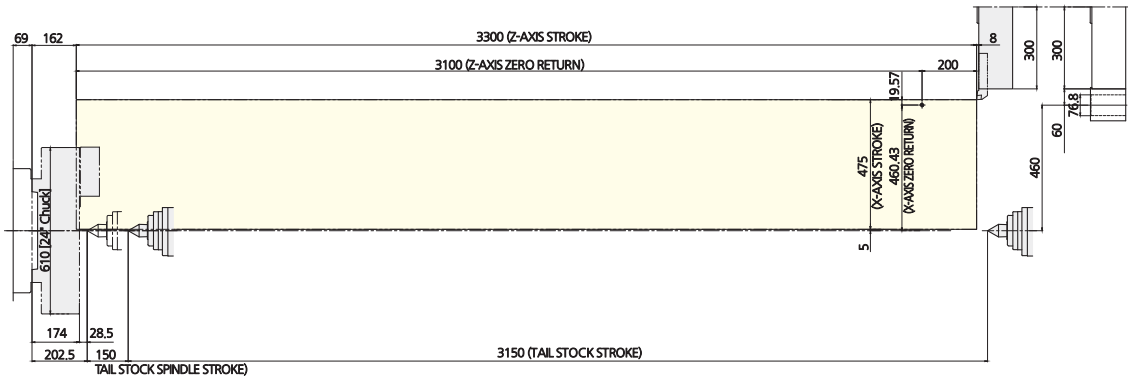

NL 6000XLM

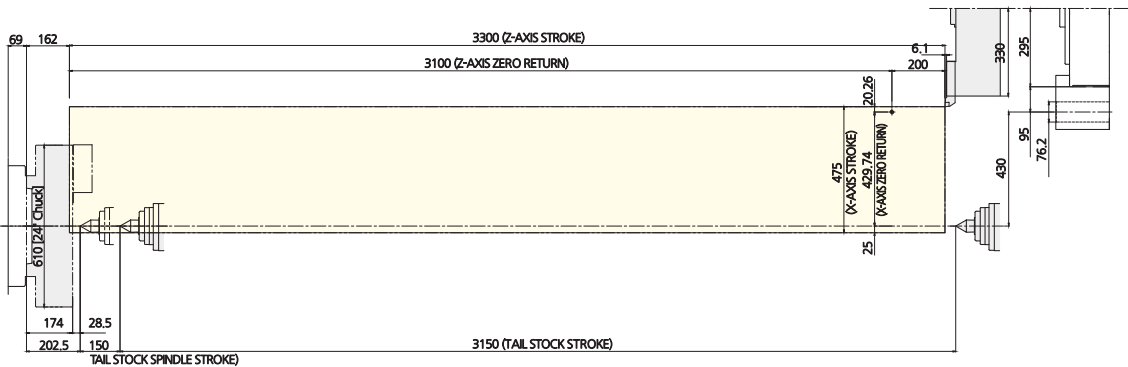

SMART
MACHINE TOOL

NL 4000/5000/6000
CNC Turning Centers

Work Range

Tooling System

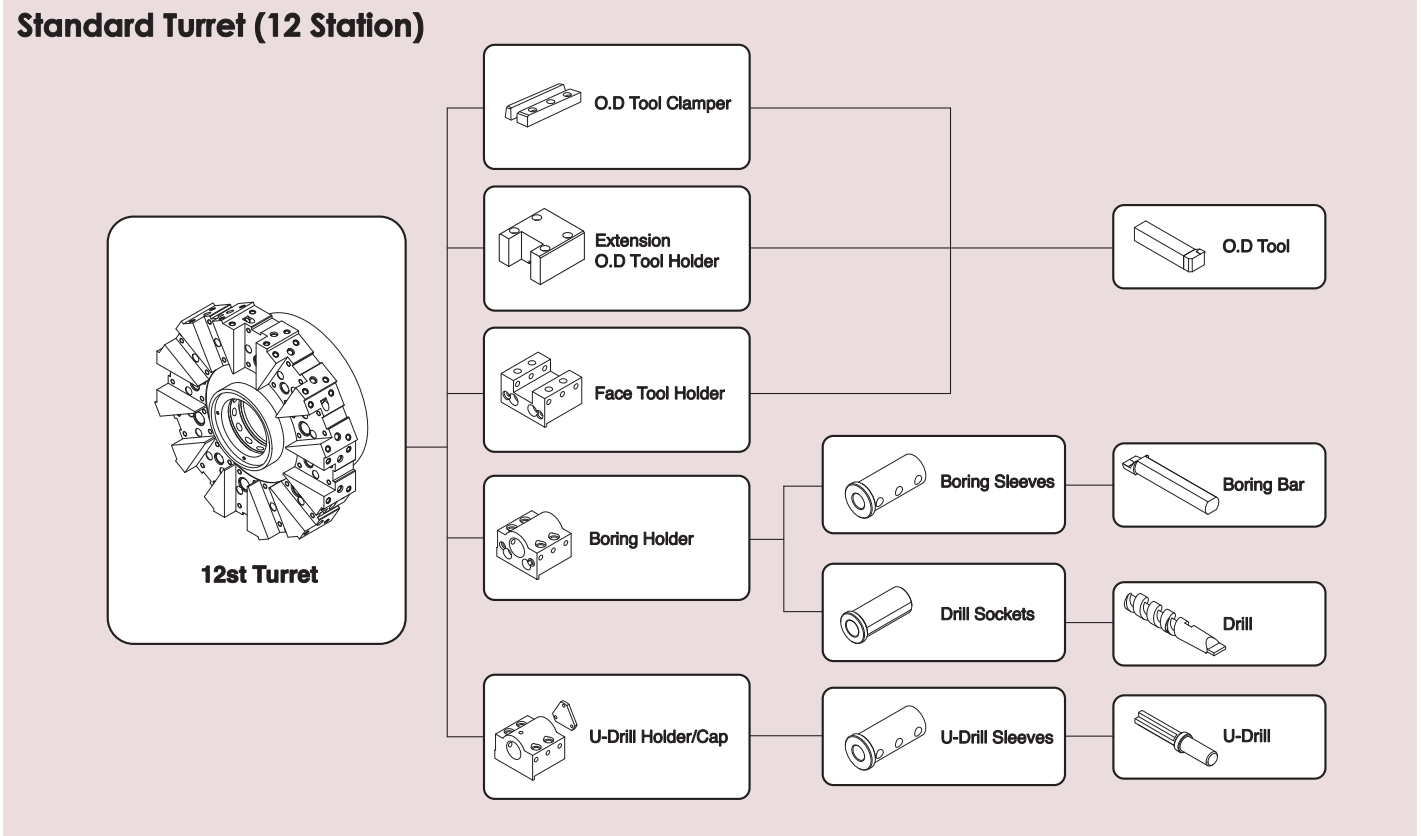

Standard Tooling Parts

Unit : mm

ITEM			NL 4000/L/XL	NL 5000/L/XL	NL 6000/S/L/XL
Turning Holder	Extension O.D holder		1	1	1
	Facing Holder		1	1	1
Boring Holder	Boring Holder	-	-	4	3
	U-Drill Holder	-	5	1	2
Driven Holder	Axial Milling Holder	Standard	-	-	-
	Radial Milling Holder	Standard	-	-	-
Sleeve	Boring	Ø12	1	1	-
		Ø16	1	1	1
		Ø20	1	1	1
		Ø25	1	1	1
		Ø32	1	1	1
		Ø40	1	1	1
		Ø50	1	1	1
		Ø60	-	-	1
	Drill	MT2	1	1	1
		MT3	1	1	1
		MT4	1	1	1
		MT5	1	1	1

BMT Turret (12 Station)

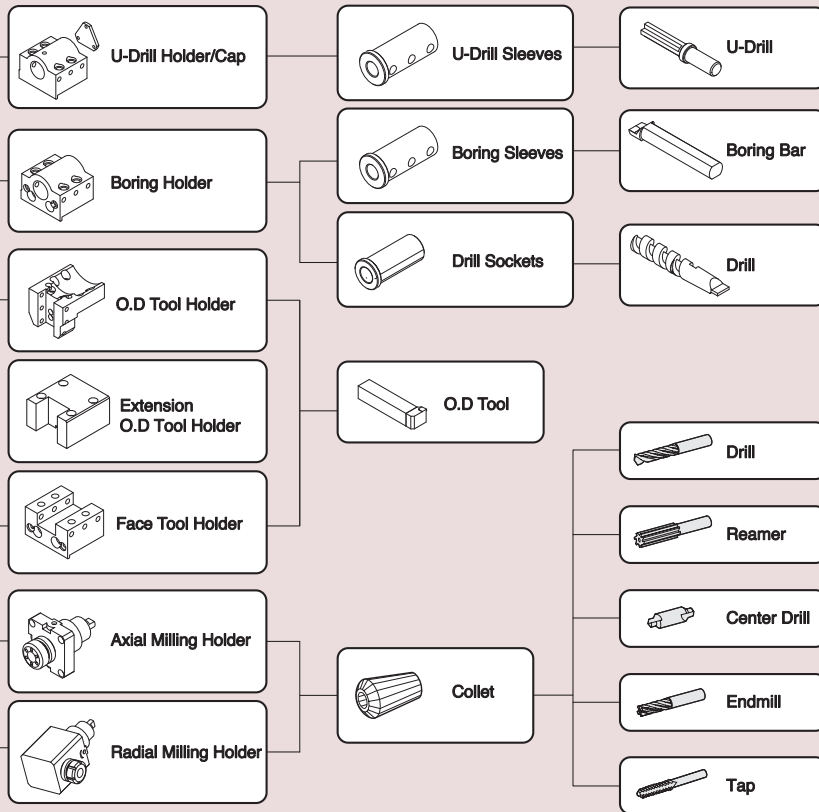
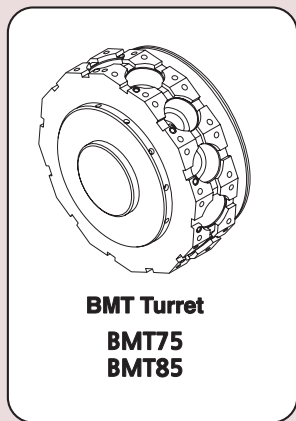

Standard Tooling Parts

Unit : mm

ITEM		NL 4000M/LM/XLM	NL 5000M/LM/XLM	NL 4000Y/NL 5000Y	NL 6000M/SM/LM/XLM	
Turning Holder	O.D Holder	1	3	1	3	
	Extension O.D Holder	3	1	3	1	
	Facing Holder	1	1	1	1	
Boring Holder	Boring Holder	-	2	2	2	
	U-Drill Holder	-	1	1	1	
Driven Holder	Axial Milling Holder	Standard	2	2	2	
	Radial Milling Holder	Standard	2	2	2	
Sleeve	Boring	Ø12	1	1	1	-
		Ø16	1	1	1	1
		Ø20	1	1	1	1
		Ø25	1	1	1	1
		Ø32	1	1	1	1
		Ø40	1	1	1	1
		Ø50	1	1	1	1
	Ø60	-	-	-	1	
	Drill	MT2	1	1	1	1
		MT3	1	1	1	1
		MT4	1	1	1	1
MT5		1	1	1	1	

Machine Specifications

DESCRIPTION			NL 4000 [L/XL]	NL 4000M [LM/XLM]	NL 4000LY
CAPACITY	Swing over the bed	mm	790		900
	Swing over the cross slide	mm	610		850
	Max. machining diameter	mm	648	638	550
	Max. machining length	mm	1,213 [2,213/3,213]	1,144 [2,144/3,144]	2,017
	Chuck size	mm	457 (18")		
	Bar working dia.	mm	116.5		
SPINDLE	Spindle speed	rpm	2,000		
	Spindle motor	kW	30/45		
	Spindle nose	ASA	A2 - 11		
	Spindle torque	N.m	3,283		2,687
	Spindle through hole dia.	mm	132		
TRAVEL	Rapid traverse (X/Z/Y)	m/min	16/20		16/20/10
	X-axis travel	mm	340		300
	Z-axis travel	mm	1,300 [2,300/3,300]		2,155
	Y-axis travel	mm	-		150
	Feed motor (X/Z/Y)	kW	4/7 [XL/XLM: 4/6]		7/6/7
TURRET	Number of tool stations	st.	12		
	OD tool size	mm	□ 32		
	Max. boring bar size	mm	Ø60		
	Indexing time	sec	0.25/step		
	Milling tool holder type	-	-	BMT75	
	Max. rotary tool spindle speed	rpm	-	4,000	
	Rotary tool motor power	kW	-	7.5/11/15	
TAILSTOCK	Tailstock travel	mm	1,165 [2,165/3,165]		2,077
	Quill diameter	mm	140		
	Quill travel	mm	120		
	Taper of tailstock spindle	-	MT#5 (Built-in)		
BED TYPE	-	45° Slant			
ELECTRIC POWER SUPPLY	kVA	55			
REQUIRED FLOOR SPACE	mm	4,450x2,017 [5,720x2,205/6,720x2,275]		5,720x2,340	
MACHINE WEIGHT	kg	10,700 [13,600/16,700]	10,800 [13,700/16,800]	14,800	
CONTROLLER	-	Fanuc 0i-TF Plus			

DESCRIPTION		NL 5000 [L/XL]	NL 5000M [LM/XLM]	NL 5000LY	
CAPACITY	Swing over the bed	mm	900		
	Swing over the cross slide	mm	690	850	
	Max. machining diameter	mm	670	650	550
	Max. machining length	mm	1,155 [2,155/3,155]	1,119 [2,119/3,119]	1,992
	Chuck size	mm	533 (21")		
	Bar working dia.	mm	165.5		
SPINDLE	Spindle speed	rpm	1,500		
	Spindle motor	kW	30/45		
	Spindle nose	ASA	A2 - 15		
	Spindle torque	N.m	3,955	3105	
	Spindle through hole dia.	mm	181		
TRAVEL	Rapid traverse (X/Z/Y)	m/min	16/20	16/20/10	
	X-axis travel	mm	350	300	
	Z-axis travel	mm	1,300 [2,300/3,300]	2,155	
	Y-axis travel	mm	-	150	
	Feed motor (X/Z/Y)	kW	7/6	7/6/7	
TURRET	Number of tool stations	st.	12		
	OD tool size	mm	□ 32		
	Max. boring bar size	mm	Ø60		
	Indexing time	sec	0.25/step		
	Milling tool holder type	-	-	BMT75	
	Max. rotary tool spindle speed	rpm	-	4,000	
	Rotary tool motor power	kW	-	7.5/11/15	
TAILSTOCK	Tailstock travel	mm	1,165 [2,165/3,165]	2,077	
	Quill diameter	mm	140		
	Quill travel	mm	120		
	Taper of tailstock spindle	-	MT#5(Built-in)		
BED TYPE	-	45° Slant			
ELECTRIC POWER SUPPLY	kVA	55			
REQUIRED FLOOR SPACE	mm	4,450x2,017 [5,720x2,205/6,720x2,275]		5,720x2,340	
MACHINE WEIGHT	kg	10,800 [13,700/16,800]	10,900 [13,800/16,900]	15,000	
CONTROLLER	-	Fanuc 0i-TF Plus			

SMART
MACHINE TOOL

NL 4000/5000/6000
CNC Turning Centers

Machine specifications

Machine Specifications

DESCRIPTION			NL 6000S	NL 6000SM	NL 6000 [C]	NL 6000M
CAPACITY	Swing over the bed	mm	1,030			
	Swing over the cross slide	mm	850			
	Max. machining diameter	mm	960	900	960	900
	Max. machining length	mm	750	700	1,550	1,500
	Chuck size	mm	610 (24")		610 (24") [user scope]	610 (24")
	Bar working dia.	mm	165.5		165.5 [-]	165.5
SPINDLE	Spindle speed	rpm	1,200		1,200 [1,000]	1,200
	Spindle motor	kW	37/55			
	Spindle nose	ASA	A1 - 15		A1 - 15 [A1 - 20]	A1 - 15
	Spindle torque	N.m	5,143			
	Spindle through hole dia.	mm	181		181 [275]	181
TRAVEL	Rapid traverse (X/Z)	m/min	16/20			
	Travel (X/Z)	mm	475/800		475/1,600	
	Feed motor (X/Z)	kW	7/6			
TURRET	Number of tool stations	st.	12			
	OD tool size	mm	□ 32			
	Max. boring bar size	mm	Ø80			
	Indexing time	sec	0.25/Step	0.35/Step	0.25/Step	0.35/Step
	Milling tool holder type	-	-	BMT85	-	BMT85
	Max. rotary tool spindle speed	rpm	-	3,000	-	3,000
	Rotary tool motor power	kW	-	7.5/11/15	-	7.5/11/15
TAILSTOCK	Tailstock travel	mm	Option		1,450	
	Quill diameter	mm	Option		180	
	Quill travel	mm	Option		150	
	Taper of tailstock spindle	-	Option		MT#6 (Built-in)	
BED TYPE	-	45° Slant				
ELECTRIC POWER SUPPLY	kVA	70				
REQUIRED FLOOR SPACE	mm	4,390x2,379			5,191x2,379	
MACHINE WEIGHT	kg	11,500	12,000	15,300	15,800	
CONTROLLER	-	Fanuc Oi-TF Plus				

DESCRIPTION			NL 6000L [CL]	NL 6000LM	NL 6000XL [CXL]	NL 6000XLM
CAPACITY	Swing over the bed	mm	1,030			
	Swing over the cross slide	mm	850			
	Max. machining diameter	mm	960	900	960	900
	Max. machining length	mm	2,250	2,200	3,250	3,200
	Chuck size	mm	610 (24") [user scope]	610 (24")	610 (24") [user scope]	610 (24")
	Bar working dia.	mm	165.5 [-]	165.5	165.5 [-]	165.5
SPINDLE	Spindle speed	rpm	1,200 [1,000]	1,200	1,200 [1,000]	1,200
	Spindle motor	kW	37/55			
	Spindle nose	ASA	A1 - 15 [A1 - 20]	A1 - 15	A1 - 15 [A1 - 20]	A1 - 15
	Spindle torque	N.m	5,143			
	Spindle through hole dia.	mm	181 [275]	181	181 [275]	181
TRAVEL	Rapid traverse (X/Z)	m/min	16/20			
	Travel (X/Z)	mm	475/2,300		475/3,300	
	Feed motor (X/Z)	kW	7/6			
TURRET	Number of tool stations	st.	12			
	OD tool size	mm	□ 32			
	Max. boring bar size	mm	Ø80			
	Indexing time	sec	0.25/Step	0.35/Step	0.25/Step	0.35/Step
	Milling tool holder type	-	-	BMT85	-	BMT85
	Max. rotary tool spindle speed	rpm	-	3,000	-	3,000
	Rotary tool motor power	kW	-	7.5/11/15	-	7.5/11/15
TAILSTOCK	Tailstock travel	mm	2,150		3,150	
	Quill diameter	mm	180			
	Quill travel	mm	150			
	Taper of tailstock spindle	-	MT#6 (Built-in)			
BED TYPE	-	45° Slant				
ELECTRIC POWER SUPPLY	kVA	70				
REQUIRED FLOOR SPACE	mm	6,004x2,389			7,100x2,657	
MACHINE WEIGHT	kg	17,300	17,800	19,800	20,300	
CONTROLLER	-	Fanuc Oi-TF Plus				

SMART
MACHINE TOOLNL 4000/5000/6000
CNC Turning Centers

Machine specifications

NC Unit Specification/FANUC Series

● : Standard ○ : Option

	ITEM	Specification	Of-TF Plus
Controlled axis	Max. feed axes		2/3/4 Axis
	Feed axes		X/Z(Cs) X/Y/Z(Cs)
	Max. simultaneously controlled axis		4
	Least command increment	0.001mm / 0.0001"	●
Operation functions	Pulse handle feed	X1, X10, X100	●
	Feedrate per minute	G98	●
	Feedrate per revolution	G99	●
Interpolation functions	Linear interpolation	G01	●
	Circular interpolation	G02, G03	●
	Dwell	G04	●
	Polar coordinate interpolation	G12.1, G13.1	●
	Cylindrical interpolation	G07.1	●
	Helical interpolation		○
	Variable lead thread cutting	G34	●
	Continuous threading		●
	Reference position return	G28	●
Feed function	Reference position return check	G27	●
	Rapid traverse rate override	F0, 25%, 50%, 100%	●
Spindle function	Feedrate override	0 ~ 200%	●
	Spindle orientation		●
	Rigid tapping		●
Program Input	Arbitrary speed threading		○
	Absolute/incremental programming		●
	Multiple repetitive canned cycle	G70 ~ G76	●
	Canned cycles	G90, G92, G94	●
	Inch/metric conversion	G20 / G21	●
	Program restart		●
	Retraction for rigid tapping		○
	Max. programmable dimension	±999999.999mm/±99999.9999	●
	M function	M3 digit	●
	Custom macro		●
	Canned cycle for drilling		●
	Direct drawing dimension programming		●
	Programmable data input	G10	●
	Optional block skip		●
	Workpiece coordinate system	G52 ~ G59	●
Setting and display	Number of registerable programs		1000EA
	Alarm & Operator history display		●
	Run hour and parts count display		●
	Display spindle & servo overload		●
	Self-diagnosis function		●
	Extended part program editing		●
Data input/output	Display screen		15" Touch panel
	Memory card input/output		●
Edliting operation	USB memory input/output		●
	Part program storage size	2 Mbyte (5120m)	●
Manual guide i	Manual guide i		●